

PYCO, LLC.

600 E. LINCOLN HWY.
PENNDL, PA 19047
215-757-3704
Fax: 215-757-3780
info@pyco.com
www.pyco.com

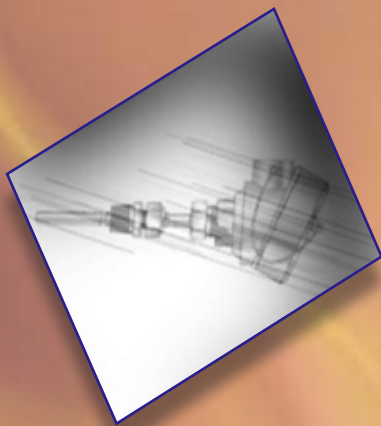

Inlet Sensors

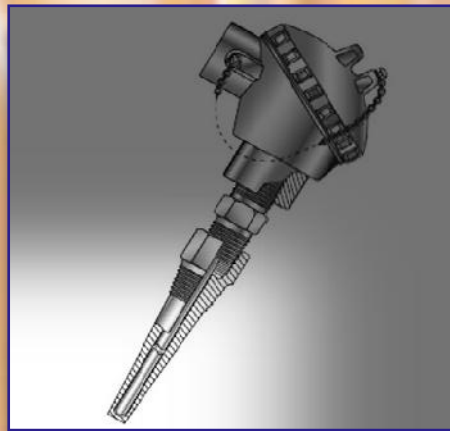

Industrial Assemblies

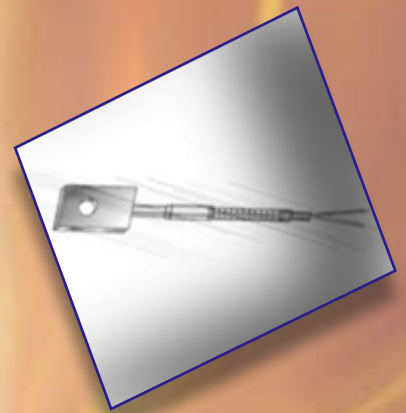

Gasket / Tube Skin Sensors

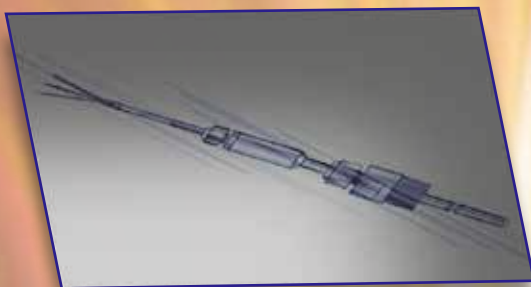

Immersion Sensors



Turbine Sensors

POWER • OIL & GAS • PETROCHEMICAL • BIOTECH

OUR KNOWLEDGE • YOUR PROCESS • OUR PRODUCTS



A PyroSense Group Company



Who Are We!

Pyco Inc. has been a leading manufacturer of temperature sensors since 1957. It has been a company focused on building relations and providing solutions to your temperature sensor needs. An all American company that has established a solid working relationship with some of the best engineering firms and manufactures of Industrial equipment.

*In 2015 the assets of **Pyco Inc.** were bought by the PyroSense Group. The group was established to service the global temperature sensor Industry. Our **PYCO** brand will continue to service the temperature sensor needs under **PYCO LLC**. The new **PYCO** will service the world from its Pennel, PA and its Fairfield, NJ facility.*

Our new combine 80 year's experience will allow us to expand our services to the Power Industry and will also bring value to other sectors such as Oil & Gas, Chemical, Transportation and Cement.

***Our Mission:** To become a value added temperature sensor supplier to our customers while building long lasting relationships, one client at a time. To rely on service, quality and to build a business that our employees can be proud to be a part of.*

YOUR INDUSTRY

**YOUR PROCESS
OUR KNOWLEDGE**

OUR SENSORS



Our Management

Jose Alberto—President: With over 18 years experience serving the Global temperature sensor markets. Jose has been building Relations and helping clients design a better solutions for their process all around the world.

Lou Saia—VP Engineering: Mr. Saia has been serving the Industry for over 37 years. He has been an innovator in design, engineering and manufacturing of critical and noncritical sensors for the industry.

Julio Morales—VP Operations: Has been serving the temperature sensor business for over 27 years. From operations, Procurements, Logistics and Manufacturing. Mr. Morales has the experience to meet the customers expectations.

YOUR INDUSTRY

**YOUR PROCESS
OUR KNOWLEDGE**

OUR SENSORS



Our Industry

- **POWER**
- **Oil & GAS**
- **CHEMICAL**
- **TRANSPORTATION**
- **CEMENT**



PYCO, MANUFACTURES SENSORS ACCORDING TO YOUR SPECIFICATIONS. WE WILL BE GLAD TO WORK WITH YOU TO DESIGN A CUSTOM SENSOR TO MEET YOUR PROCESS REQUIREMENTS.

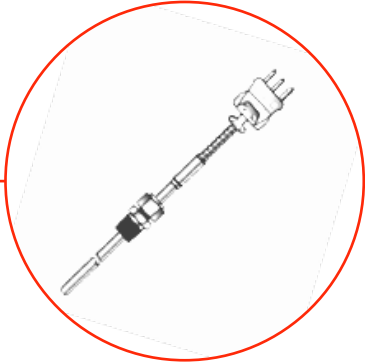

Miniature Sensors: The basic sensor is used in all aspects of temperature monitoring. **PYCO** sensors are made of multiple constructions and can reach temperatures as high as 3100 Deg. F.

Gasket: The gasket sensors are use in all application that requires a constant fix sensor. These sensors can be welded on, bolted on or bayonet style.

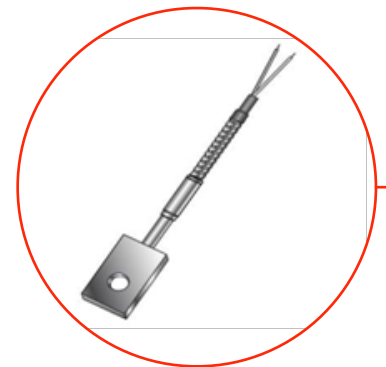

Tube Skin: The tube skin t/c is used in Refineries to measure the furnaces, tube walls and is also the ideal sensor for the boilers.

“Increases furnace efficiency”

Assemblies: The Industrial assemblies are use in harsh environment. Most often in the process vessels, reactors, and pipelines. These can be made in Thermocouples or RTD's.

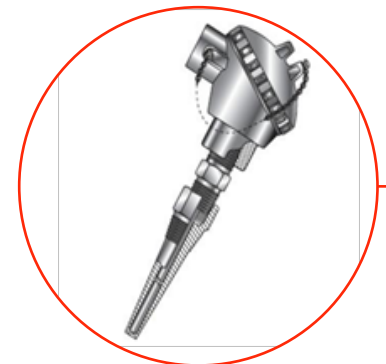

Specialty Sensors: **PYCO** designs specialty sensors to meet your specifications or we will work with you to help you design a sensor that will fit your process



THERMOCOUPLES

IMMERSION SENSOR

IMMERSION SENSORS, SOMETIMES CALLED MINIATURE THERMOCOUPLES COME IN ALL CALIBRATIONS AND RANGE IN DIAMETER FROM .040" TO .375". AVAILABLE IN VARIOUS SHEATH MATERIALS, THEY ALSO COME IN SINGLE OR DUPLEX CONSTRUCTION. IN DIRECT CONTACT WITH THE PROCESS TEMPERATURE, THEY CAN HAVE FIXED FITTINGS ATTACHED TO THE SHEATH OR HAVE ADJUSTABLE COMPRESSION FITTINGS. THE PROBE CAN HAVE A DIRECT CONNECTOR TERMINATED TO THE SHEATH OR WITH EXTENSION LEAD WIRE ATTACHED TO THE PROBE.

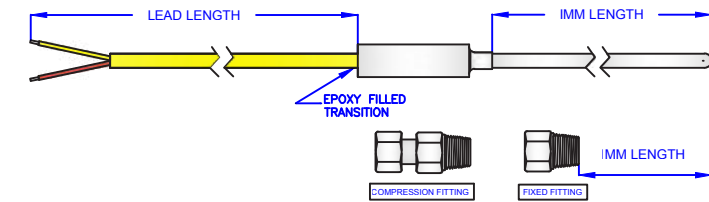

BAYONET SENSOR

BAYONET THERMOCOUPLES USE A SPRING AND LOCKING CAP TO KEEP THE SENSOR HOT JUNCTION IN CONSTANT CONTACT WITH THE SURFACE OF THE PROCESS. USED WITH BAYONET ADAPTORS THAT COME IN VARIOUS LENGTHS TO ACCOMMODATE SPECIFIC REQUIREMENTS, THE THERMOCOUPLE LOCKS ONTO THE BAYONET ADAPTOR. BAYONET THERMOCOUPLES COME IN DIFFERENT DESIGNS AND STYLES TO MEET ALL APPLICATION REQUIREMENTS.

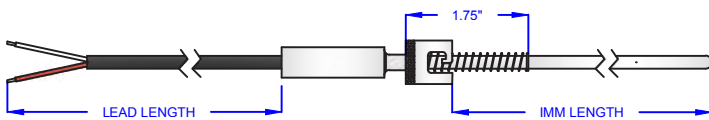

TUBE SKIN SENSOR

THE TUBESKIN SENSOR HAS A WELD PAD WELDED TO THE THERMOCOUPLE SHEATH. IT IS ATTACHED TO THE PROCESS BY WELDING OR CLAMPING IT TO THE SURFACE SO THE SENSOR IS IN CONTACT WITH THE PROCESS SKIN TEMPERATURE. TUBESKIN SENSORS COME IN SEVERAL STYLES TO MEET ALL APPLICATION REQUIREMENTS.

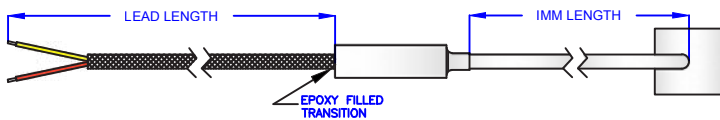

GASKET SENSOR

THE GASKET SENSOR HAS A GASKET WELDED OR SOLDERED TO THE THERMOCOUPLE SHEATH. IT IS ATTACHED TO THE PROCESS BY BOLTING TO A STUD ON THE SURFACE SO THE SENSOR IS IN CONTACT WITH THE PROCESS SKIN TEMPERATURE. GASKET SENSORS COME IN SEVERAL STYLES TO MEET APPLICATION REQUIREMENTS.

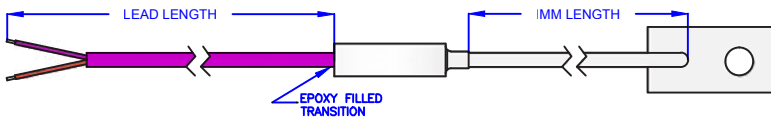

PLASTIC MELT SENSOR

THE PLASTIC MELT SENSOR IS USED MOSTLY ON EXTRUDERS IN THE PLASTICS INDUSTRY. THEY HAVE A MELT BOLT SOLDERED TO THE THERMOCOUPLE SHEATH THAT SCREWS INTO THE PROCESS AND THE SENSING HOT JUNCTION IS IN CONTACT WITH THE MOLTEN PLASTIC. THEY COME IN VARIOUS STYLES AND LENGTHS TO MEET SPECIFIC REQUIREMENTS.

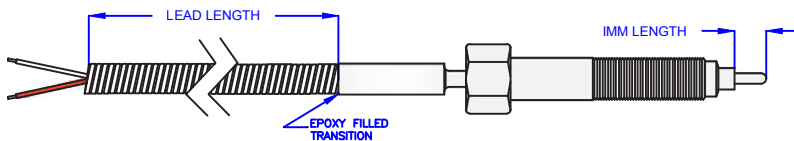

IMMERSION THERMOCOUPLE

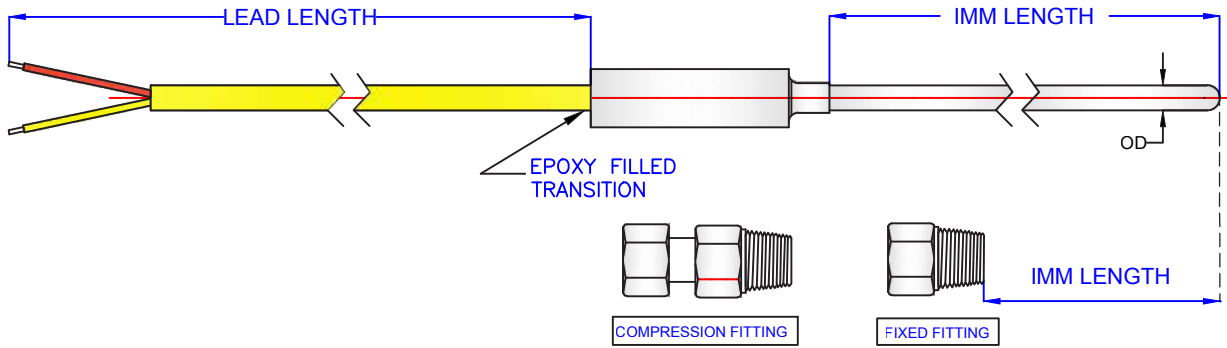

EXAMPLE ORDERING CODE:

IMM TC - 125 - KS - G - 304 - 0 - 12 - 24 - G - SP



Diagram showing the mapping of the ordering code to various specifications:

- TYPE**: Points to the first digit of the code.
- PROBE DIAMETER**: Points to the second digit of the code.
- CALIBRATION (ADD S FOR SPECIAL LIMITS)**: Points to the third digit of the code.
- MEASURING JUNCTION**: Points to the fourth digit of the code.
- SHEATH MATERIAL**: Points to the fifth digit of the code.
- PROCESS CONNECTION**: Points to the sixth digit of the code.
- LEAD LENGTH**: Points to the seventh and eighth digits of the code.
- LEAD TYPE**: Points to the ninth digit of the code.
- TERMINATION**: Points to the tenth digit of the code.

PROBE DIAMETER	
040	.040" OD
062	.062" OD
125	.125" OD
187	.187" OD
250	.250" OD
312	.312" OD
375	.375" OD

CALIBRATION (ADD S FOR SPECIAL LIMITS)	
J	IRON/CONSTANTAN
K	CHROMAL/ALUMEL
T	COPPER/CONSTANTAN
E	CHROMEL/CONSTANTAN
JJ	DUAL IRON/CONSTANTAN
KK	DUAL CHROMAL/ALUMEL
TT	DUAL COPPER/CONSTANTAN
EE	DUAL CHROMEL/CONSTANTAN

MEASURING JUNCTION	
G	GROUNDED
U	UNGROUNDED
E	EXPOSED LOOP

SHEATH MATERIAL	
CS	CARBON STEEL
304	304 STAINLESS
316	316 STAINLESS
600	INCONEL 600

CODE	PROCESS CONNECTION	THREAD
0	NONE	
1	316 SS COMP FITTING	1/8"
2	316 SS COMP FITTING W/TEFLON INSERT	1/4"
3	BRASS COMP FITTING	1/2"
4	BRASS COMP FITTING W/TEFLON INSERT	
5	SS FIXED FITTING	

TERMINATION	
BE	BARE ENDS
SP	STANDARD PLUG
SJ	STANDARD JACK
MP	MINI PLUG
MJ	MINI JACK
CP	CERAMIC PLUG
CJ	CERAMIC JACK
HP	HI TEMP PLUG
HJ	HI TEMP JACK
DP	DUAL PLUG
DJ	DUAL JACK

LEAD TYPE	
G	GLASS
T	TEFLON
SB	STAINLESS BRAID
AC	ARMOR CABLE

DESIGNS FOR THE RIGHT APPLICATION

SPECIAL DESIGNS OR MATERIALS UPON REQUEST

MEETS ANSI AND ASTM STANDARDS FOR THERMOCOUPLE CALIBRATION TOLERANCES



BAYONET THERMOCOUPLE

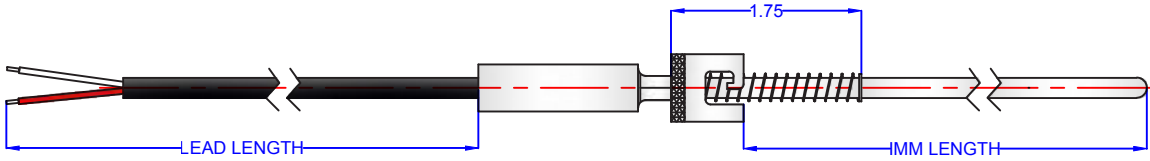

BAY - 187 - J - G - 304 - HD - 2.38 - 1.5 - 2.13 - 24 - G - BE

TYPE		PROBE DIAMETER		CALIBRATION (ADD S FOR SPECIAL LIMITS)		IMM LENGTH		IMM RANGE		TERMINATION		LEAD TYPE	
BAY BAY90		125 187	.125" OD .187" OD	J K T E JJ KK TT EE	IRON/CONSTANTAN CHROMAL/ALUMEL COPPER/CONSTANTAN CHROMEL/CONSTANTAN DUAL IRON/CONSTANTAN DUAL CHROMAL/ALUMEL DUAL COPPER/CONSTANTAN DUAL CHROMEL/CONSTANTAN	2 2.38 2.88 3.38 4.38 4.88 5.38 5.88 6.38 6.88 7.38 7.88 8.38	1.13"-1.75" 1.5"-2.13" 2"-2.63" 3"-3.63" 3.5"-4.13" 4"-4.63" 4.5"-5.13" 5"-5.63" 5.5"-6.13" 6"-6.63" 6.5"-7.13" 7"-7.63" 7.5"-8.13"	BE SP SJ MP MJ CP CJ HP HJ DP DJ	BARE ENDS STANDARD PLUG STANDARD JACK MINI PLUG MINI JACK CERAMIC PLUG CERAMIC JACK HI TEMP PLUG HI TEMP JACK DUAL PLUG DUAL JACK	G T SB AC	GLASS TEFLON STAINLESS BRAID ARMOR CABLE		
MEASURING JUNCTION		SHEATH		CONSTRUCTION						LEAD LENGTH			
G U	GROUND ED UNGROUND ED	310 304 316 600	310 STAINLESS 304 STAINLESS 316 STAINLESS INCONEL 600	LD HD	LIGHT DUTY (TUBE CONSTRUCTION) HEAVY DUTY (MI CABLE CONSTRUCTION)								

DESIGNS FOR THE RIGHT APPLICATION

SPECIAL DESIGNS OR MATERIALS UPON REQUEST

LT DESIGN IN 304 OR 316 STAINLESS SHEATH ONLY

MEETS ANSI AND ASTM STANDARDS FOR THERMOCOUPLE CALIBRATION TOLERANCES



TUBE SKIN THERMOCOUPLE

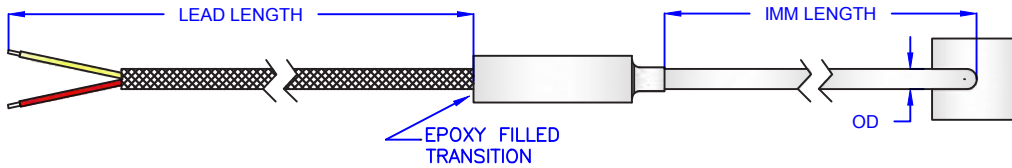

EXAMPLE ORDERING CODE:

TS TC - 125 - KS - G - 304 - 1 - L3 - 12 - 24 - G - SP

↑	↑	↑	↑	↑	↑	↑	↑	↑	↑	↑																								
TYPE																																		
<table border="1" style="width: 100%; border-collapse: collapse;"> <thead> <tr> <th colspan="2">PROBE DIAMETER</th> </tr> </thead> <tbody> <tr> <td>125</td> <td>.125" OD</td> </tr> <tr> <td>187</td> <td>.187" OD</td> </tr> <tr> <td>250</td> <td>.250" OD</td> </tr> <tr> <td>312</td> <td>.312" OD</td> </tr> </tbody> </table>		PROBE DIAMETER		125	.125" OD	187	.187" OD	250	.250" OD	312	.312" OD																							
PROBE DIAMETER																																		
125	.125" OD																																	
187	.187" OD																																	
250	.250" OD																																	
312	.312" OD																																	
<table border="1" style="width: 100%; border-collapse: collapse;"> <thead> <tr> <th colspan="2">CALIBRATION (ADD S FOR SPECIAL LIMITS)</th> </tr> </thead> <tbody> <tr> <td>J</td> <td>IRON/CONSTANTAN</td> </tr> <tr> <td>K</td> <td>CHROMAL/ALUMEL</td> </tr> <tr> <td>T</td> <td>COPPER/CONSTANTAN</td> </tr> <tr> <td>E</td> <td>CHROMEL/CONSTANTAN</td> </tr> <tr> <td>JJ</td> <td>DUAL IRON/CONSTANTAN</td> </tr> <tr> <td>KK</td> <td>DUAL CHROMAL/ALUMEL</td> </tr> <tr> <td>TT</td> <td>DUAL COPPER/CONSTANTAN</td> </tr> <tr> <td>EE</td> <td>DUAL CHROMEL/CONSTANTAN</td> </tr> </tbody> </table>		CALIBRATION (ADD S FOR SPECIAL LIMITS)		J	IRON/CONSTANTAN	K	CHROMAL/ALUMEL	T	COPPER/CONSTANTAN	E	CHROMEL/CONSTANTAN	JJ	DUAL IRON/CONSTANTAN	KK	DUAL CHROMAL/ALUMEL	TT	DUAL COPPER/CONSTANTAN	EE	DUAL CHROMEL/CONSTANTAN															
CALIBRATION (ADD S FOR SPECIAL LIMITS)																																		
J	IRON/CONSTANTAN																																	
K	CHROMAL/ALUMEL																																	
T	COPPER/CONSTANTAN																																	
E	CHROMEL/CONSTANTAN																																	
JJ	DUAL IRON/CONSTANTAN																																	
KK	DUAL CHROMAL/ALUMEL																																	
TT	DUAL COPPER/CONSTANTAN																																	
EE	DUAL CHROMEL/CONSTANTAN																																	
<table border="1" style="width: 100%; border-collapse: collapse;"> <thead> <tr> <th colspan="2">MEASURING JUNCTION</th> </tr> </thead> <tbody> <tr> <td>G</td> <td>GROUNDED</td> </tr> <tr> <td>U</td> <td>UNGROUNDED</td> </tr> </tbody> </table>		MEASURING JUNCTION		G	GROUNDED	U	UNGROUNDED																											
MEASURING JUNCTION																																		
G	GROUNDED																																	
U	UNGROUNDED																																	
<table border="1" style="width: 100%; border-collapse: collapse;"> <thead> <tr> <th colspan="2">PROBE SHEATH</th> </tr> </thead> <tbody> <tr> <td>304</td> <td>304 STAINLESS</td> </tr> <tr> <td>316</td> <td>316 STAINLESS</td> </tr> <tr> <td>310</td> <td>310 STAINLESS</td> </tr> <tr> <td>600</td> <td>INCONEL 600</td> </tr> </tbody> </table>		PROBE SHEATH		304	304 STAINLESS	316	316 STAINLESS	310	310 STAINLESS	600	INCONEL 600																							
PROBE SHEATH																																		
304	304 STAINLESS																																	
316	316 STAINLESS																																	
310	310 STAINLESS																																	
600	INCONEL 600																																	
<table border="1" style="width: 100%; border-collapse: collapse;"> <thead> <tr> <th>CODE</th> <th>WELD PAD SIZE</th> </tr> </thead> <tbody> <tr> <td>1</td> <td>1" X 1" X 1/8"</td> </tr> <tr> <td>2</td> <td>1" X 1" X 1/16"</td> </tr> </tbody> </table>		CODE	WELD PAD SIZE	1	1" X 1" X 1/8"	2	1" X 1" X 1/16"																											
CODE	WELD PAD SIZE																																	
1	1" X 1" X 1/8"																																	
2	1" X 1" X 1/16"																																	
<table border="1" style="width: 100%; border-collapse: collapse;"> <thead> <tr> <th colspan="2">TERMINATION</th> </tr> </thead> <tbody> <tr> <td>BE</td> <td>BARE ENDS</td> </tr> <tr> <td>SP</td> <td>STANDARD PLUG</td> </tr> <tr> <td>SJ</td> <td>STANDARD JACK</td> </tr> <tr> <td>MP</td> <td>MINI PLUG</td> </tr> <tr> <td>MJ</td> <td>MINI JACK</td> </tr> <tr> <td>CP</td> <td>CERAMIC PLUG</td> </tr> <tr> <td>CJ</td> <td>CERAMIC JACK</td> </tr> <tr> <td>HP</td> <td>HI TEMP PLUG</td> </tr> <tr> <td>HJ</td> <td>HI TEMP JACK</td> </tr> <tr> <td>DP</td> <td>DUAL PLUG</td> </tr> <tr> <td>DJ</td> <td>DUAL JACK</td> </tr> </tbody> </table>		TERMINATION		BE	BARE ENDS	SP	STANDARD PLUG	SJ	STANDARD JACK	MP	MINI PLUG	MJ	MINI JACK	CP	CERAMIC PLUG	CJ	CERAMIC JACK	HP	HI TEMP PLUG	HJ	HI TEMP JACK	DP	DUAL PLUG	DJ	DUAL JACK									
TERMINATION																																		
BE	BARE ENDS																																	
SP	STANDARD PLUG																																	
SJ	STANDARD JACK																																	
MP	MINI PLUG																																	
MJ	MINI JACK																																	
CP	CERAMIC PLUG																																	
CJ	CERAMIC JACK																																	
HP	HI TEMP PLUG																																	
HJ	HI TEMP JACK																																	
DP	DUAL PLUG																																	
DJ	DUAL JACK																																	
<table border="1" style="width: 100%; border-collapse: collapse;"> <thead> <tr> <th colspan="2">LEAD TYPE</th> </tr> </thead> <tbody> <tr> <td>G</td> <td>GLASS</td> </tr> <tr> <td>T</td> <td>TEFLON</td> </tr> <tr> <td>SB</td> <td>STAINLESS BRAID</td> </tr> <tr> <td>AC</td> <td>ARMOR CABLE</td> </tr> </tbody> </table>		LEAD TYPE		G	GLASS	T	TEFLON	SB	STAINLESS BRAID	AC	ARMOR CABLE																							
LEAD TYPE																																		
G	GLASS																																	
T	TEFLON																																	
SB	STAINLESS BRAID																																	
AC	ARMOR CABLE																																	
<table border="1" style="width: 100%; border-collapse: collapse;"> <thead> <tr> <th>LEAD LENGTH</th> </tr> </thead> <tbody> <tr> <td>12</td> </tr> </tbody> </table>		LEAD LENGTH	12																															
LEAD LENGTH																																		
12																																		
<table border="1" style="width: 100%; border-collapse: collapse;"> <thead> <tr> <th>IMM LENGTH</th> </tr> </thead> <tbody> <tr> <td>24</td> </tr> </tbody> </table>		IMM LENGTH	24																															
IMM LENGTH																																		
24																																		
<table border="1" style="width: 100%; border-collapse: collapse;"> <thead> <tr> <th>CODE</th> <th>MOUNT</th> <th>PIPE OD</th> </tr> </thead> <tbody> <tr> <td>F</td> <td>FLAT</td> <td>ENTER IN INCHES</td> </tr> <tr> <td>L</td> <td>LONGITUDINAL</td> <td></td> </tr> <tr> <td>R</td> <td>RIGHT ANGLE</td> <td></td> </tr> </tbody> </table>		CODE	MOUNT	PIPE OD	F	FLAT	ENTER IN INCHES	L	LONGITUDINAL		R	RIGHT ANGLE																						
CODE	MOUNT	PIPE OD																																
F	FLAT	ENTER IN INCHES																																
L	LONGITUDINAL																																	
R	RIGHT ANGLE																																	

IMMERSION CAN BE BENT FOR EXPANSION

SPECIAL DESIGNS OR MATERIALS UPON REQUEST

MEETS ANSI AND ASTM STANDARDS FOR THERMOCOUPLE CALIBRATION TOLERANCES



GASKET THERMOCOUPLE

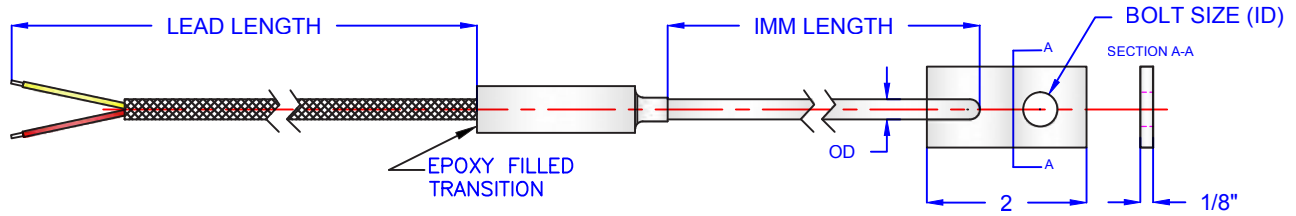

EXAMPLE ORDERING CODE:

GS TC - 125 - KS - G - 304 - 3 - 12 - 24 - G - SP



TYPE

PROBE DIAMETER	
125	.125" OD
187	.187" OD
250	.250" OD
312	.312" OD

TERMINATION	
BE	BARE ENDS
SP	STANDARD PLUG
SJ	STANDARD JACK
MP	MINI PLUG
MJ	MINI JACK
CP	CERAMIC PLUG
CJ	CERAMIC JACK
HP	HI TEMP PLUG
HJ	HI TEMP JACK
DP	DUAL PLUG
DJ	DUAL JACK

CALIBRATION (ADD S FOR SPECIAL LIMITS)	
J	IRON/CONSTANTAN
K	CHROMAL/ALUMEL
T	COPPER/CONSTANTAN
E	CHROMEL/CONSTANTAN
JJ	DUAL IRON/CONSTANTAN
KK	DUAL CHROMAL/ALUMEL
TT	DUAL COPPER/CONSTANTAN
EE	DUAL CHROMEL/CONSTANTAN

LEAD TYPE	
G	GLASS
T	TEFLON
SB	STAINLESS BRAID
AC	ARMOR CABLE

MEASURING JUNCTION	
G	GROUND
U	UNGROUND

LEAD LENGTH

IMM LENGTH

PROBE SHEATH	
304	304 STAINLESS
316	316 STAINLESS
310	310 STAINLESS
600	INCONEL 600

CODE	BOLT SIZE	ID
1	#6	.144"
2	#8	3/16"
3	#10	13/64"
4	#12	7/32"
5	1/4"	9/32"
6	5/16"	11/32"
7	3/8"	13/32"

IMMERSION CAN HAVE 90 DEG BEND

SPECIAL DESIGNS OR MATERIALS UPON REQUEST

MEETS ANSI AND ASTM STANDARDS FOR THERMOCOUPLE CALIBRATION TOLERANCES



INDUSTRIAL TUBE SKIN THERMOCOUPLE

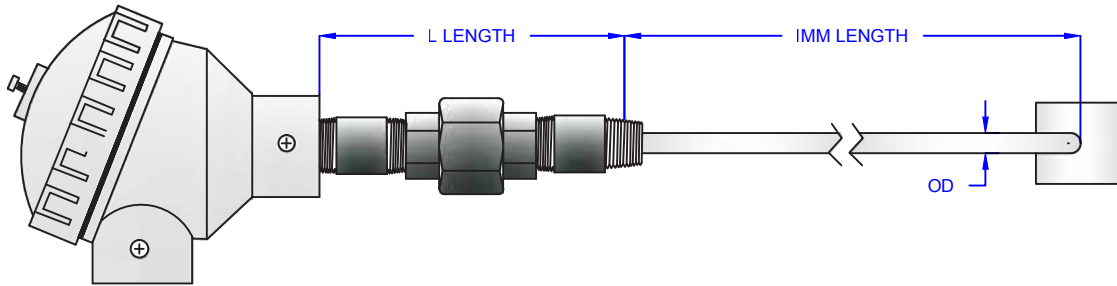

EXAMPLE ORDERING CODE:

IND TSTC - 250 - JS - G - 304 - L3 - 48 - 6 - AL

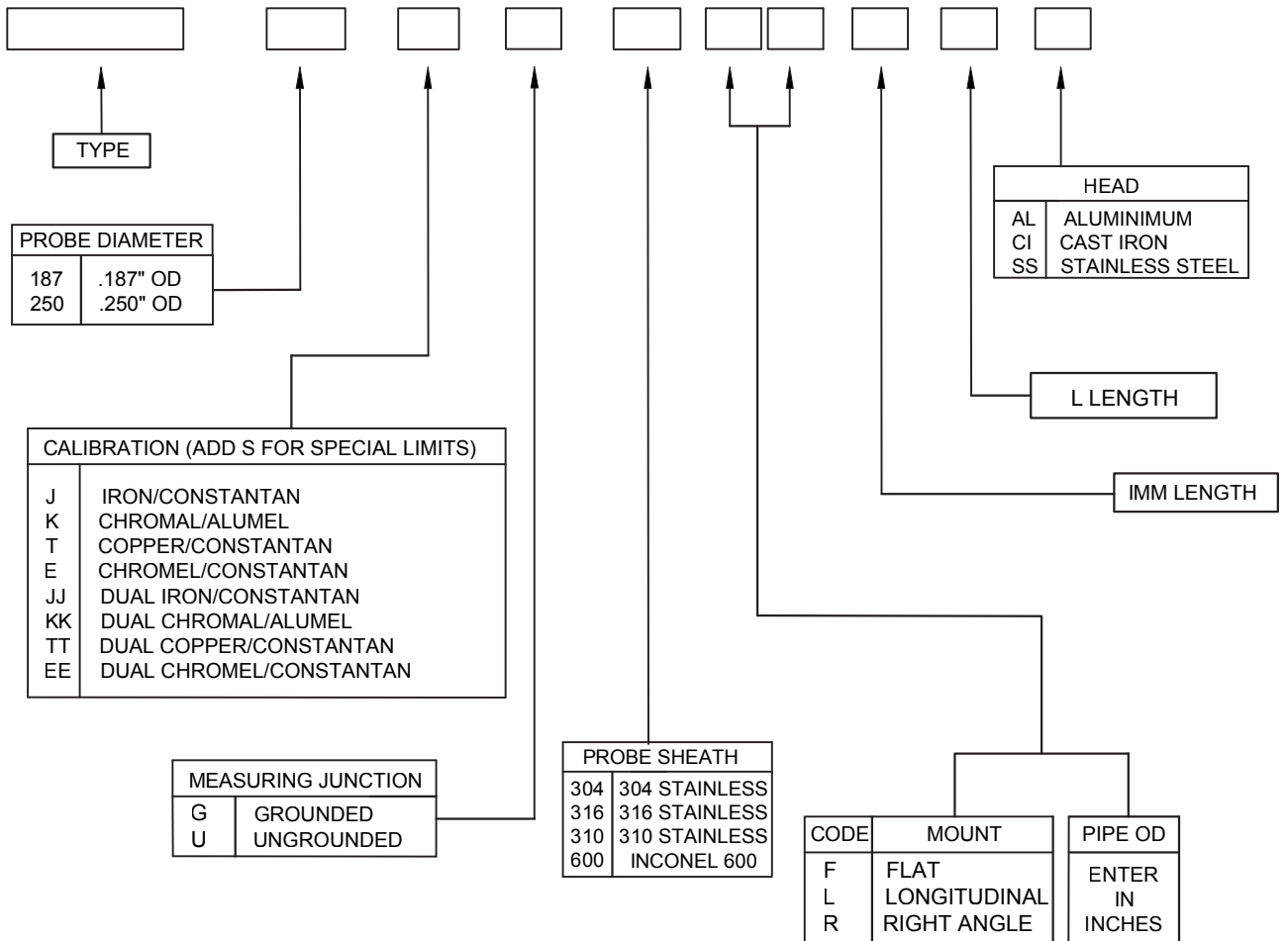

IMMERSION CAN BE BENT FOR EXPANSION

SPECIAL DESIGNS OR MATERIALS UPON REQUEST

MEETS ANSI AND ASTM STANDARDS FOR THERMOCOUPLE CALIBRATION TOLERANCES



SEMI INDUSTRIAL THERMOCOUPLE

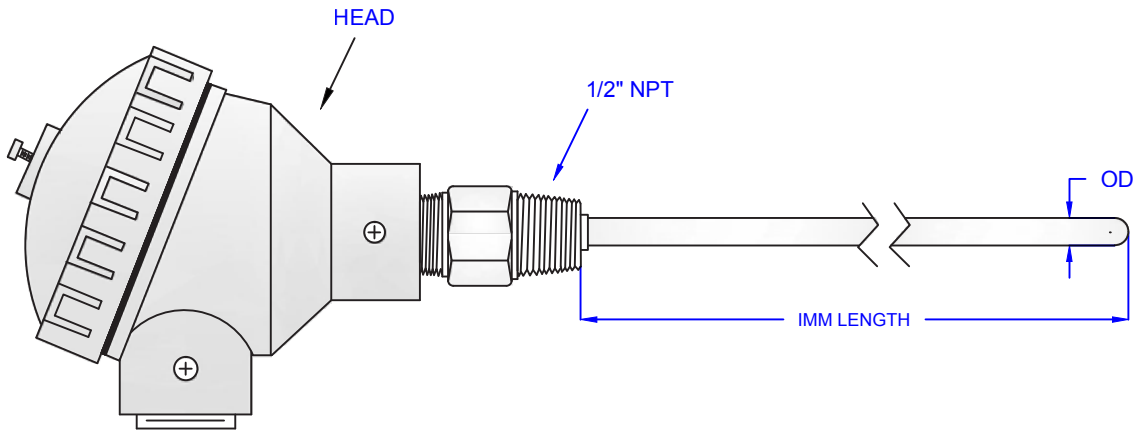

EXAMPLE ORDERING CODE:

TC1001 - AL - 304 - 250 - K - G - 12 - ST - S



MODEL NUMBER										S SINGLE D DUAL
HEAD										TOLERANCE
AL ALUMINUM CI CAST IRON SS STAINLESS										ST STANDARD SP SPECIAL
SHEATH										IMM LENGTH
CS CARBON STEEL 304 304 STAINLESS 316 316 STAINLESS 600 INCONEL 600										MEASURING JUNCTION
PROBE DIAMETER										G GROUNDED U UNGROUNDED E EXPOSED LOOP
125 .125" OD 187 .187" OD 250 .250" OD 312 .312" OD 375 .375" OD										
CALIBRATION										
J IRON/CONSTANTAN K CHROMAL/ALUMEL T COPPER/CONSTANTAN E CHROMEL/CONSTANTAN										

RUGGED MINERAL INSULATED CABLE DESIGN
 SPECIAL DESIGNS OR MATERIALS UPON REQUEST
 MEETS ANSI AND ASTM STANDARDS FOR THERMOCOUPLE CALIBRATION TOLERANCES
 CAN BE SUPPLIED IN FIXED OR SPRING LOADED CONSTRUCTIONS



STANDARD WIRE TYPES

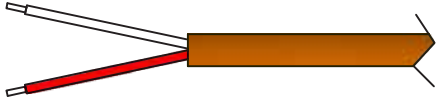

TYPE G

TYPE G WIRE HAS FIBERGLASS INSULATION OVER EACH CONDUCTOR WITH A FIBERGLASS JACKET OVERALL

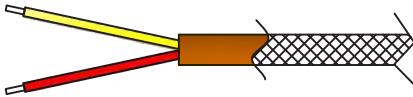

TYPE SB

TYPE SB WIRE HAS FIBERGLASS INSULATION OVER EACH CONDUCTOR WITH A FIBERGLASS JACKET AND A STAINLESS STEEL BRAID OVERALL

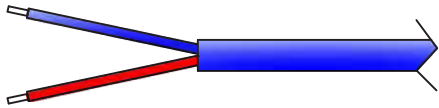

TYPE T

TYPE T WIRE HAS FEP TEFLON INSULATION OVER EACH CONDUCTOR WITH AN FEP TEFLON JACKET OVERALL

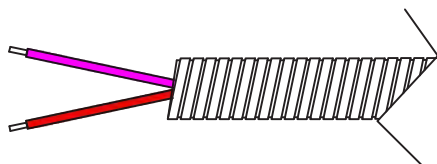

TYPE AC

TYPE SB WIRE HAS FIBERGLASS INSULATION OVER EACH CONDUCTOR WITH A FIBERGLASS JACKET AND A STAINLESS STEEL BRAID OVERALL

NON STANDARD WIRE WITH DIFFERENT SIZES, INSULATIONS OR CONFIGURATIONS CAN BE PROVIDED UPON REQUEST BY USING "SP" FOR THE TYPE. THE SPECIFICATION OF THE WIRE MUST BE SUPPLIED.



TERMINATION TYPES

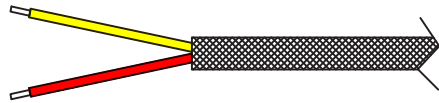

TYPE BE

BARE END TERMINATION

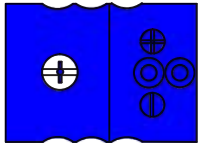

TYPE SJ

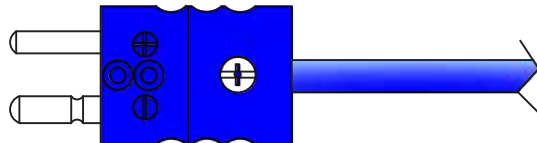

TYPE SP

STANDARD AND MINI CONNECTORS ARE GLASS FILLED THERMOPLASTIC RATED TO 390 DEG F. PLUGS HAVE

THERMOCOUPLE MATERIAL PINS AND JACKS HAVE THERMOCOUPLE MATERIAL SPRINGLOADED INSERTS.

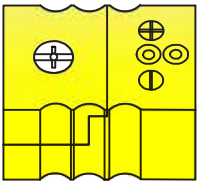

TYPE DJ

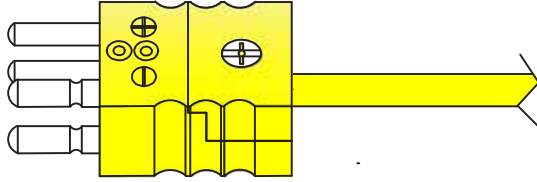

TYPE DP

HI TEMP CONNECTORS ARE THERMOSET RATED TO 690 DEG F. PLUGS HAVE THERMOCOUPLE MATERIAL PINS AND JACKS HAVE THERMOCOUPLE MATERIAL SPRINGLOADED INSERTS.

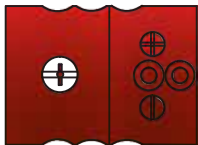

TYPE HJ

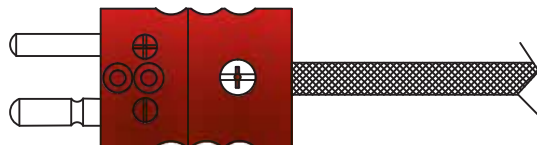

TYPE HP

CERAMIC CONNECTORS ARE RATED TO 1,200 DEG F AND PLUGS HAVE THERMOCOUPLE MATERIAL PINS AND JACKS HAVE THERMOCOUPLE MATERIAL SPRINGLOADED INSERTS.

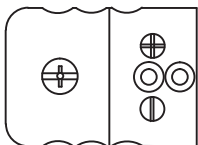

TYPE CJ

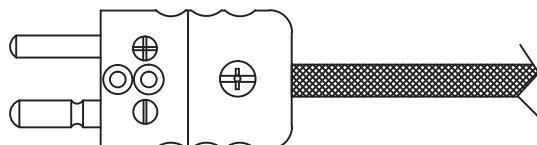

TYPE CP



TYPE MJ



TYPE MP



INDUSTRIAL SENSORS

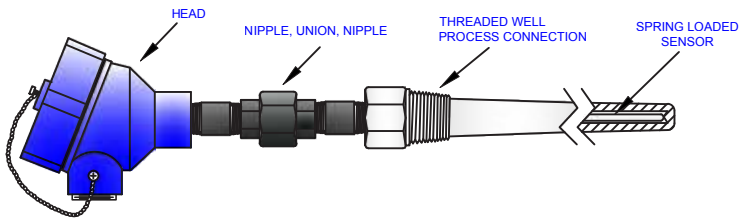

THREADED THERMOWELL SENSOR

THE THREADED HEAVY DUTY INDUSTRIAL SENSOR WITH THE THERMOWELL MADE FROM SOLID BARSTOCK. SCREWED INTO THE PROCESS SO THE THERMOWELL HOUSING THE SENSOR IS IN CONTACT WITH THE PROCESS TEMPERATURE. THERMOWELLS COME IN TAPERED, STRAIGHT, OR STEPPED DESIGNS.

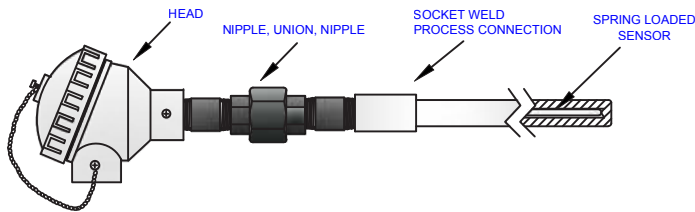

SOCKET-WELD AND WELD-IN THERMOWELL SENSOR

THE SOCKET-WELD AND WELD-IN HEAVY DUTY INDUSTRIAL SENSOR WITH THE THERMOWELL MADE FROM SOLID BARSTOCK. WELDED INTO THE PROCESS SO THE THERMOWELL HOUSING THE SENSOR IS IN CONTACT WITH THE PROCESS TEMPERATURE. WELD-IN THERMOWELLS ARE TAPERED. SOCKET-WELD THERMOWELLS COME IN TAPERED, STRAIGHT, OR STEPPED DESIGNS.

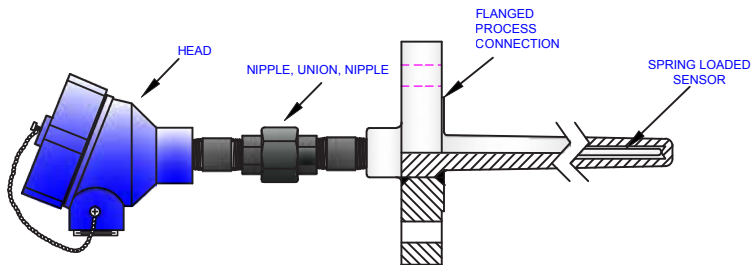

FLANGED THERMOWELL SENSOR

THE FLANGED HEAVY DUTY INDUSTRIAL SENSOR HAS A FLANGE WELDED TO THE SOLID BARSTOCK THERMOWELL. FLANGE SIZE AND RATING MATCH THE EXISTING PROCESS FLANGE. THE THERMOWELL HOUSING THE SENSOR IS IN CONTACT WITH THE PROCESS TEMPERATURE. FLANGED THERMOWELLS COME IN TAPERED, STRAIGHT, OR STEPPED DESIGNS.

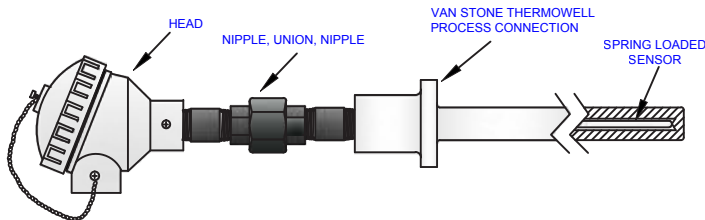

VAN STONE THERMOWELL SENSOR

THE VAN STONE HEAVY DUTY INDUSTRIAL SENSOR IS MADE FROM SOLID BARSTOCK. USED WITH A BACKING FLANGE (NOT SHOWN) IT IS SANDWICHED ONTO THE PROCESS FLANGE. THE THERMOWELL HOUSING THE SENSOR IS IN CONTACT WITH THE PROCESS TEMPERATURE. VAN STONE THERMOWELLS COME IN TAPERED OR STRAIGHT DESIGNS.

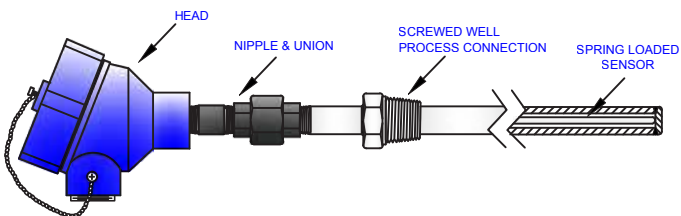

PIPE THERMOWELL SENSOR

THE PIPE WELL INDUSTRIAL SENSOR OFFERS PROTECTION TO THE SENSOR BUT IS MORE COST EFFECTIVE THAN BARSTOCK THERMOWELLS. THEY GO INTO THE PROCESS SO THE THERMOWELL HOUSING THE SENSOR IS IN CONTACT WITH THE PROCESS TEMPERATURE. PIPE WELL THERMOWELLS DESIGNS COME IN FLANGED, THREADED, OR WITH NO PROCESS CONNECTION.

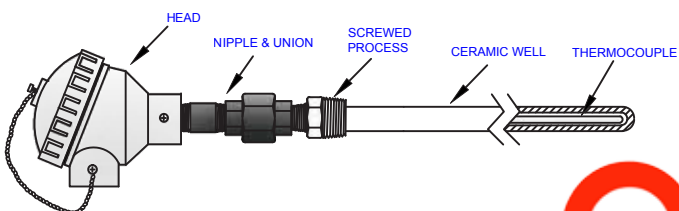

CERAMIC THERMOWELL SENSOR

THE CERAMIC WELL INDUSTRIAL SENSOR IS USUALLY USED AT VERY HIGH TEMPERATURES AND OFFERS PROTECTION TO THE THERMOCOUPLE. IT GOES INTO THE PROCESS SO THE THERMOWELL HOUSING THE SENSOR IS IN CONTACT WITH THE PROCESS TEMPERATURE. CERAMIC WELL THERMOWELLS COME IN THREADED OR FLANGED PROCESS CONNECTIONS.



INDUSTRIAL THERMOCOUPLE - THREADED WELL

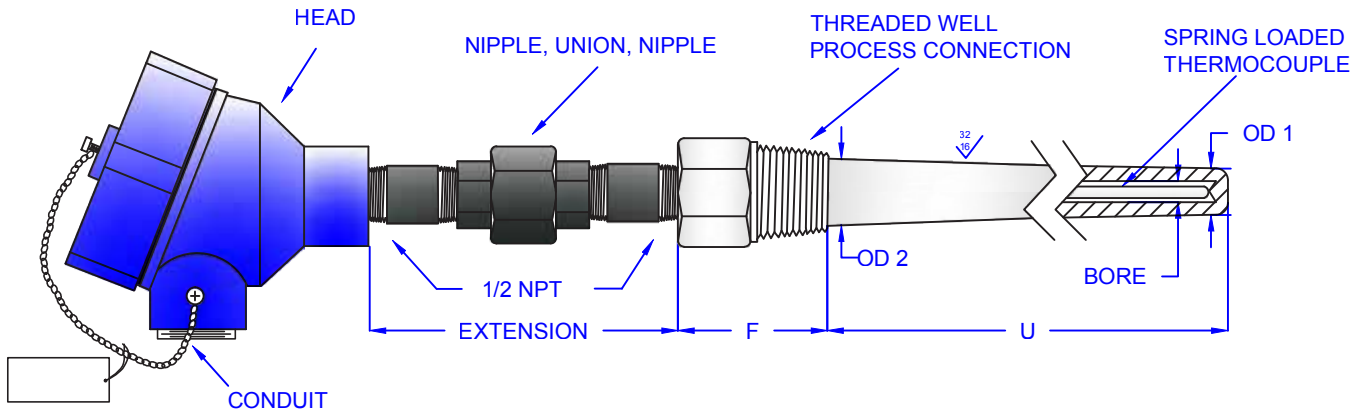

EXAMPLE ORDERING CODE:

IND TC - AX - 3/4 - 250 - 304 - K - G - NUN6 - 02 - 316 - 1.75 - 4.5



MODEL NUMBER

HEAD	
AL	STANDARD ALUMINUM
AX	ALUMINUM EXPLOSION PROOF
CI	CAST IRON
SS	STAINLESS STEEL

CONDUIT THREAD	
1/2	1/2" NPT
3/4	3/4" NPT

PROBE DIAMETER	
125	.125" OD
187	.187" OD
250	.250" OD
312	.312" OD
375	.375" OD

PROBE SHEATH	
304	304 STAINLESS
316	316 STAINLESS
310	310 STAINLESS
600	INCONEL 600

CALIBRATION (ADD S FOR SPECIAL LIMITS)	
J	IRON/CONSTANTAN
K	CHROMAL/ALUMEL
T	COPPER/CONSTANTAN
E	CHROMEL/CONSTANTAN
JJ	DUAL IRON/CONSTANTAN
KK	DUAL CHROMAL/ALUMEL
TT	DUAL COPPER/CONSTANTAN
EE	DUAL CHROMEL/CONSTANTAN

U LENGTH

F LENGTH
(1.75" STD)

WELL MATERIAL	
CS	CARBON STEEL
304	304 STAINLESS
316	316 STAINLESS
600	INCONEL 600

THERMOWELL TYPE	
01	1/2" SCREWED TAPERED .63 TO .50 WITH .260 BORE
02	3/4" SCREWED TAPERED .88 TO .75 WITH .260 BORE
03	3/4" SCREWED TAPERED .88 TO .75 WITH .385 BORE
04	1" SCREWED TAPERED 1.10 TO .75 WITH .260 BORE
05	1" SCREWED TAPERED 1.10 TO .75 WITH .385 BORE
06	1/2" SCREWED STRAIGHT .63 OD WITH .260 BORE
07	3/4" SCREWED STRAIGHT .75 OD WITH .260 BORE
08	3/4" SCREWED STRAIGHT .75 OD WITH .385 BORE
09	1" SCREWED STRAIGHT .75 OD WITH .260 BORE
10	1" SCREWED STRAIGHT .75 OD WITH .385 BORE
11	3/4" SCREWED STEPPED WITH .260 BORE
12	1" SCREWED STEPPED WITH .260 BORE

EXTENSION - LENGTH		
N	NIPPLE	3"
NUN	NIPPLE, UNION, NIPPLE	6"

JUNCTION	
G	GROUNDED
U	UNGROUNDED



INDUSTRIAL THERMOCOUPLE - SOCKET WELD & WELD IN

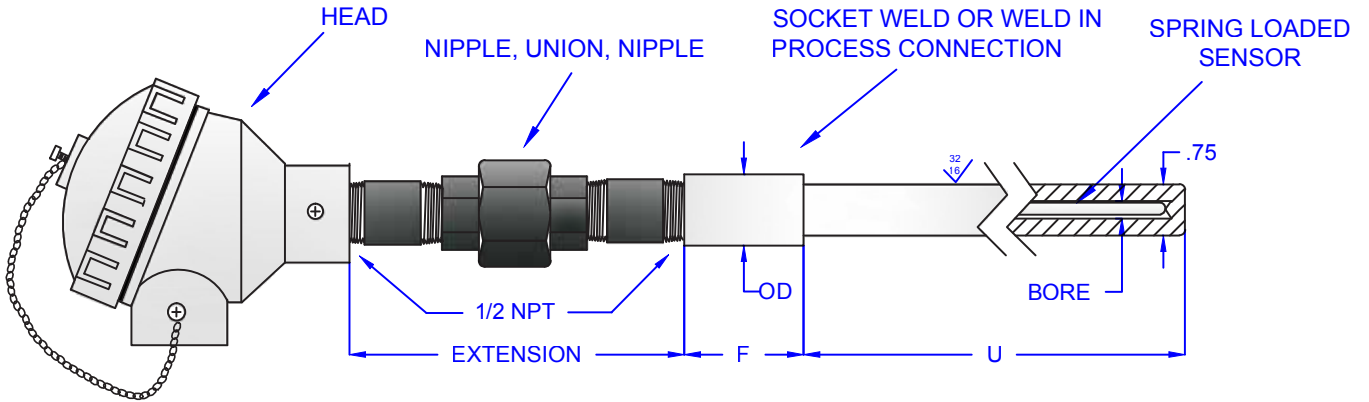

EXAMPLE ORDERING CODE:

IND TC - AL - 3/4 - 250 - 304 - K - G - NUN6 - 17 - 316 - 1.75 - 4.5



MODEL NUMBER

HEAD	
AL	STANDARD ALUMINUM
AX	ALUMINUM EXPLOSION PROOF
CI	CAST IRON
SS	STAINLESS STEEL

CONDUIT THREAD	
1/2	1/2" NPT
3/4	3/4" NPT

PROBE DIAMETER	
125	.125" OD
187	.187" OD
250	.250" OD
312	.312" OD
375	.375" OD

PROBE SHEATH	
304	304 STAINLESS
316	316 STAINLESS
310	310 STAINLESS
600	INCONEL 600

CALIBRATION (ADD S FOR SPECIAL LIMITS)	
J	IRON/CONSTANTAN
K	CHROMAL/ALUMEL
T	COPPER/CONSTANTAN
E	CHROMEL/CONSTANTAN
JJ	DUAL IRON/CONSTANTAN
KK	DUAL CHROMAL/ALUMEL
TT	DUAL COPPER/CONSTANTAN
EE	DUAL CHROMEL/CONSTANTAN

U LENGTH

F LENGTH (1.75" STD)

WELL MATERIAL	
CS	CARBON STEEL
304	304 STAINLESS
316	316 STAINLESS
600	INCONEL 600

THERMOWELL TYPE	
13	WELD IN 1.25" OD TAPERED WITH .260 BORE
14	WELD IN 1.25" OD TAPERED WITH .385 BORE
15	WELD IN 1.5" OD TAPERED WITH .260 BORE
16	WELD IN 1.5" OD TAPERED WITH .385 BORE
17	SOCKET WELD 1.05" OD TAPERED WITH .260 BORE
18	SOCKET WELD 1.05" OD TAPERED WITH .385 BORE
19	SOCKET WELD 1.315" OD TAPERED WITH .260 BORE
20	SOCKET WELD 1.315" OD TAPERED WITH .385 BORE
21	SOCKET WELD 1.05" OD STRAIGHT WITH .260 BORE
22	SOCKET WELD 1.05" OD STRAIGHT WITH .385 BORE
23	SOCKET WELD 1.315" OD STRAIGHT WITH .260 BORE
24	SOCKET WELD 1.315" OD STRAIGHT WITH .385 BORE

1.05" OD HAS .88 TO .75 TAPER *1.315" OD HAS 1.063 TO .75 TAPER*

EXTENSION - LENGTH		
N	NIPPLE	3"
NUN	NIPPLE, UNION, NIPPLE	6"

JUNCTION	
G	GROUNDED
U	UNGROUNDED



INDUSTRIAL THERMOCOUPLE - FLANGED WELL

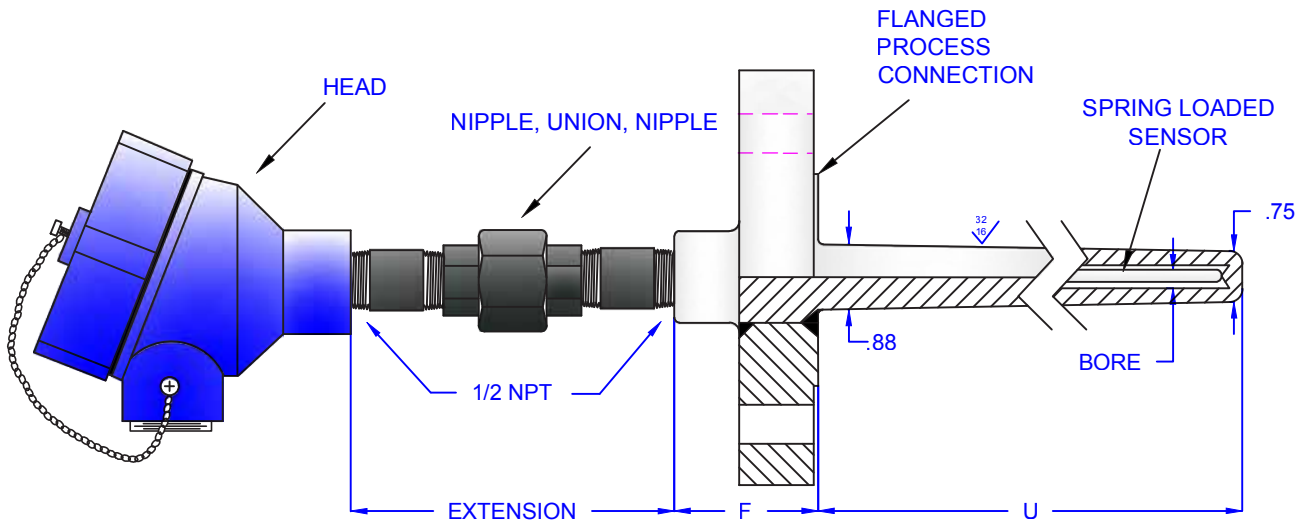

EXAMPLE ORDERING CODE:

IND TC - AE - 3/4 - 250 - 304 - K - G - NUN6 - 25 - 316 - 1.75 - 4.5



MODEL NUMBER

HEAD	
AL	STANDARD ALUMINUM
AX	ALUMINUM EXPLOSION PROOF
CI	CAST IRON
SS	STAINLESS STEEL

CONDUIT THREAD	
1/2	1/2" NPT
3/4	3/4" NPT

PROBE DIAMETER	
125	.125" OD
187	.187" OD
250	.250" OD
312	.312" OD
375	.375" OD

PROBE SHEATH	
304	304 STAINLESS
316	316 STAINLESS
310	310 STAINLESS
600	INCONEL 600

CALIBRATION (ADD S FOR SPECIAL LIMITS)	
J	IRON/CONSTANTAN
K	CHROMAL/ALUMEL
T	COPPER/CONSTANTAN
E	CHROMEL/CONSTANTAN
JJ	DUAL IRON/CONSTANTAN
KK	DUAL CHROMAL/ALUMEL
TT	DUAL COPPER/CONSTANTAN
EE	DUAL CHROMEL/CONSTANTAN

U LENGTH

F LENGTH
(1.75" STD)

WELL MATERIAL	
CS	CARBON STEEL
304	304 STAINLESS
316	316 STAINLESS
600	INCONEL 600

THERMOWELL TYPE	
25	RF FLANGE TAPERED WITH .260 BORE
26	RF FLANGE TAPERED WITH .385 BORE
27	FF FLANGE TAPERED WITH .260 BORE
28	FF FLANGE TAPERED WITH .385 BORE
29	RF FLANGE STRAIGHT WITH .260 BORE
30	RF FLANGE STRAIGHT WITH .385 BORE
31	FF FLANGE STRAIGHT WITH .260 BORE
32	FF FLANGE STRAIGHT WITH .385 BORE
33	RF FLANGE STEPPED WITH .260 BORE
34	RF FLANGE STEPPED WITH .385 BORE
35	FF FLANGE STEPPED WITH .260 BORE
36	FF FLANGE STEPPED WITH .385 BORE

EXTENSION - LENGTH		
N	NIPPLE	3"
NUN	NIPPLE, UNION, NIPPLE	6"

JUNCTION	
G	GROUNDED
U	UNGROUNDED



INDUSTRIAL THERMOCOUPLE - VAN STONE WELL

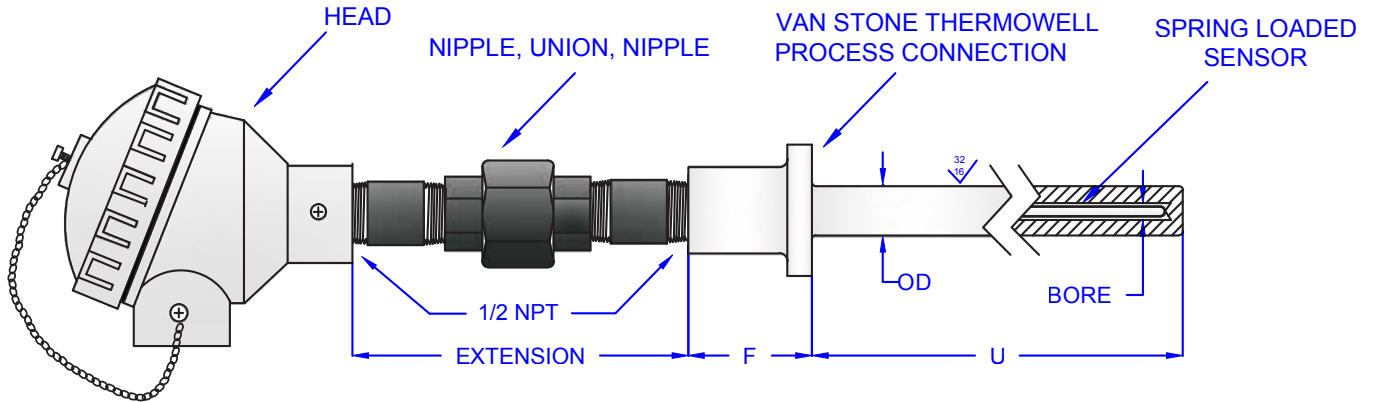

EXAMPLE ORDERING CODE:

IND TC - AL - 3/4 - 250 - 304 - K - G - NUN6 - 40 - 316 - 1.75 - 4.5



MODEL NUMBER														
HEAD													U LENGTH	
AL	STANDARD ALUMINUM											F LENGTH (1.75" STD)		
AX	ALUMINUM EXPLOSION PROOF													
CI	CAST IRON													
SS	STAINLESS STEEL													
CONDUIT THREAD														
1/2	1/2" NPT													
3/4	3/4" NPT													
PROBE DIAMETER														
125	.125" OD													
187	.187" OD													
250	.250" OD													
312	.312" OD													
375	.375" OD													
PROBE SHEATH														
304	304 STAINLESS													
316	316 STAINLESS													
310	310 STAINLESS													
600	INCONEL 600													
CALIBRATION (ADD S FOR SPECIAL LIMITS)														
J	IRON/CONSTANTAN													
K	CHROMAL/ALUMEL													
T	COPPER/CONSTANTAN													
E	CHROMEL/CONSTANTAN													
JJ	DUAL IRON/CONSTANTAN													
KK	DUAL CHROMAL/ALUMEL													
TT	DUAL COPPER/CONSTANTAN													
EE	DUAL CHROMEL/CONSTANTAN													
THERMOWELL TYPE														
37	1" PIPE SIZE, TAPERED .88 TO .75 WITH .260 BORE													
38	1" PIPE SIZE, TAPERED .88 TO .75 WITH .385 BORE													
39	1.5" PIPE SIZE, TAPERED .88 TO .75 WITH .260 BORE													
40	1.5" PIPE SIZE, TAPERED .88 TO .75 WITH .385 BORE													
41	1" PIPE SIZE, STRAIGHT .75 OD WITH .260 BORE													
42	1" PIPE SIZE, STRAIGHT .75 OD WITH .385 BORE													
43	1.5" PIPE SIZE, STRAIGHT .75 OD WITH .260 BORE													
44	1.5" PIPE SIZE, STRAIGHT .75 OD WITH .385 BORE													
WELL MATERIAL														
CS	CARBON STEEL													
304	304 STAINLESS													
316	316 STAINLESS													
600	INCONEL 600													
EXTENSION - LENGTH														
N	NIPPLE											3"		
NUN	NIPPLE, UNION, NIPPLE											6"		
JUNCTION														
G	GROUNDED													
U	UNGROUNDED													



INDUSTRIAL THERMOCOUPLE - PIPE WELL

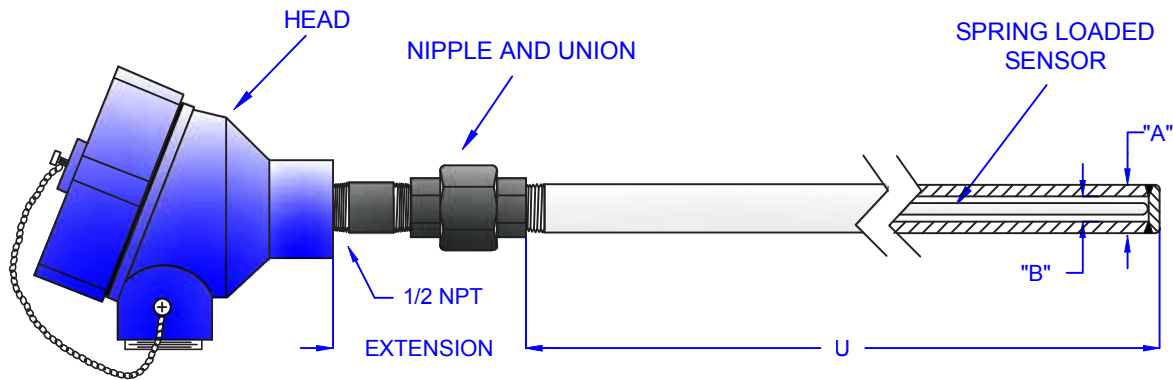

EXAMPLE ORDERING CODE:

IND TC - AL - 3/4 - 250 - 304 - K - G - NU3 - 44 - 316 - 4.5



MODEL NUMBER

HEAD	
AL	STANDARD ALUMINUM
AX	ALUMINUM EXPLOSION PROOF
CI	CAST IRON
SS	STAINLESS STEEL

CONDUIT THREAD	
1/2	1/2" NPT
3/4	3/4" NPT

PROBE DIAMETER	
125	.125" OD
187	.187" OD
250	.250" OD
312	.312" OD
375	.375" OD

PROBE SHEATH	
304	304 STAINLESS
316	316 STAINLESS
310	310 STAINLESS
600	INCONEL 600

CALIBRATION (ADD S FOR SPECIAL LIMITS)	
J	IRON/CONSTANTAN
K	CHROMAL/ALUMEL
T	COPPER/CONSTANTAN
E	CHROMEL/CONSTANTAN
JJ	DUAL IRON/CONSTANTAN
KK	DUAL CHROMAL/ALUMEL
TT	DUAL COPPER/CONSTANTAN
EE	DUAL CHROMEL/CONSTANTAN

U LENGTH

WELL MATERIAL	
CS	CARBON STEEL
304	304 STAINLESS
316	316 STAINLESS
600	INCONEL 600

THERMOWELL TYPE		
41	1/4" NPS PIPE (SCHD 40)	A= .540", B= .364"
42	1/4" NPS PIPE (SCHD 80)	A= .540", B= .302"
43	1/2" NPS PIPE (SCHD 40)	A= .840", B= .622"
44	1/2" NPS PIPE (SCHD 80)	A= .840", B= .546"
45	1/2" NPS PIPE (SCHD 160)	A= .840", B= .464"
46	3/4" NPS PIPE (SCHD 40)	A= 1.050", B= .824"
47	3/4" NPS PIPE (SCHD 80)	A= 1.050", B= .742"
48	3/4" NPS PIPE (SCHD 160)	A= 1.050", B= .612"
49	1" NPS PIPE (SCHD 40)	A= 1.315", B= 1.049"
50	1" NPS PIPE (SCHD 80)	A= 1.315", B= .957"
51	1" NPS PIPE (SCHD 160)	A= 1.315", B= .815"

EXTENSION - LENGTH		
0	NONE	0
NU	NIPPLE AND UNION	3"

JUNCTION	
G	GROUNDED
U	UNGROUNDED



INDUSTRIAL THERMOCOUPLE - PIPE WELL WITH FLANGE

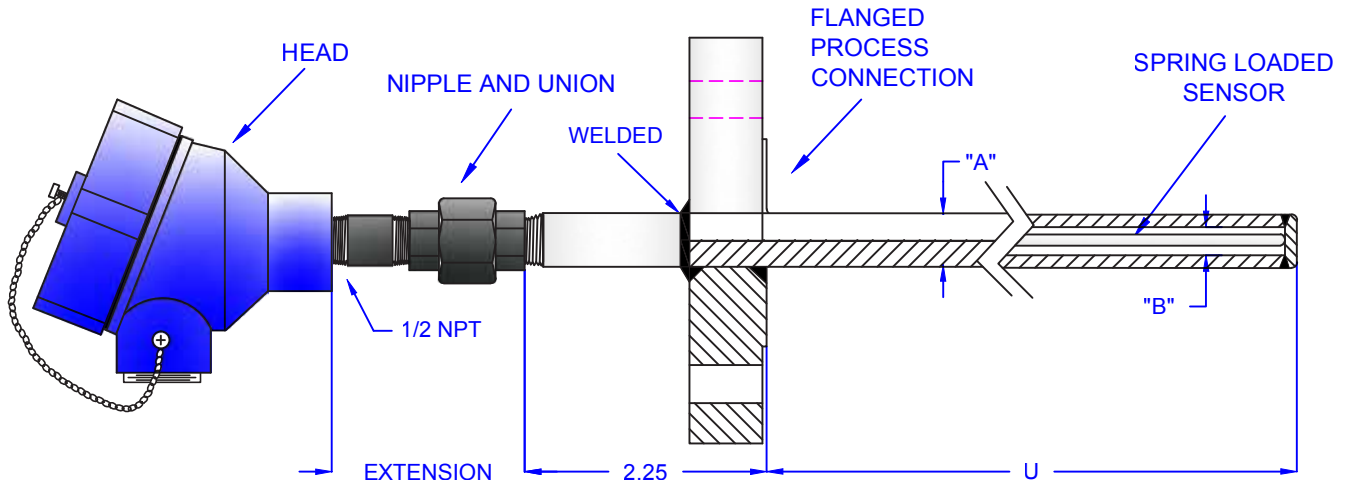

EXAMPLE ORDERING CODE:

IND TC - AL - 3/4 - 250 - 304 - K - G - NU3 - 44 - 316 - 1.5 - 150 - 4.5



MODEL NUMBER

HEAD	
AL	STANDARD ALUMINUM
AX	ALUMINUM EXPLOSION PROOF
CI	CAST IRON
SS	STAINLESS STEEL

CONDUIT THREAD	
1/2	1/2" NPT
3/4	3/4" NPT

PROBE DIAMETER	
125	.125" OD
187	.187" OD
250	.250" OD
312	.312" OD
375	.375" OD

PROBE SHEATH	
304	304 STAINLESS
316	316 STAINLESS
310	310 STAINLESS
600	INCONEL 600

CALIBRATION (ADD S FOR SPECIAL LIMITS)	
J	IRON/CONSTANTAN
K	CHROMAL/ALUMEL
T	COPPER/CONSTANTAN
E	CHROMEL/CONSTANTAN
JJ	DUAL IRON/CONSTANTAN
KK	DUAL CHROMAL/ALUMEL
TT	DUAL COPPER/CONSTANTAN
EE	DUAL CHROMEL/CONSTANTAN

U LENGTH

FLANGE RATING

FLANGE SIZE

WELL MATERIAL	
CS	CARBON STEEL
304	304 STAINLESS
316	316 STAINLESS
600	INCONEL 600

THERMOWELL TYPE		
63	1/4" NPS PIPE (SCHEDULE 40)	"A"= .540", "B"= .364"
64	1/4" NPS PIPE (SCHEDULE 80)	"A"= .540", "B"= .302"
65	1/2" NPS PIPE (SCHEDULE 40)	"A"= .840", "B"= .622"
66	1/2" NPS PIPE (SCHEDULE 80)	"A"= .840", "B"= .546"
67	1/2" NPS PIPE (SCHEDULE 160)	"A"= .840", "B"= .464"
68	3/4" NPS PIPE (SCHEDULE 40)	"A"= 1.050", "B"= .824"
69	3/4" NPS PIPE (SCHEDULE 80)	"A"= 1.050", "B"= .742"
70	3/4" NPS PIPE (SCHEDULE 160)	"A"= 1.050", "B"= .612"
71	1" NPS PIPE (SCHEDULE 40)	"A"= 1.315", "B"= 1.049"
72	1" NPS PIPE (SCHEDULE 80)	"A"= 1.315", "B"= .957"
73	1" NPS PIPE (SCHEDULE 160)	"A"= 1.315", "B"= .815"

EXTENSION - LENGTH		
0	NONE	0
NU	NIPPLE AND UNION	3"

JUNCTION	
G	GROUNDED
U	UNGROUNDED





Other Products

Accessories:

- Connectors
- Housing
- Wire
- ThermoWells
- Transmitters



Complete Solution Provider



PYCO AND THE POWER PEOPLE: A PARTNERSHIP OF EXCELLENCE

All of our efforts at PYCO are dedicated to meeting the needs of our clients in the power industry who depend on the accuracy and reliability of our products and services.

By working together, we have achieved excellence in engineering and fabricating instruments that define the industry standards in heat sensing and heat control critical to producing electric power.

In addition to manufacturing equipment of the highest quality, PYCO assures its application is maximized in plants by providing seminar programs for those who purchase, install and monitor heat sensing equipment. The results have been gratifying.

We are proud of all PYCO's achievements since our founding in 1958. Described below are some innovations that we feel are most important to our friends in power generation and to the original equipment manufacturers and architect engineers who serve them.

- When the Westinghouse Electric Corporation wanted a virtually indestructible thermocouple for blade path and compressor discharge temperature measurements in their gas turbines, PYCO responded with "long life headless thermocouple assemblies" in 1973. Westinghouse introduced them as retrofits for their customers' turbines in the field. They are recommended for use in all turbines from W-31 to W-251 frames.
- PYCO produced the first of our present TT7 thermocouples for Pratt & Whitney Jet Engines in 1974, at the request of Public Service Electric & Gas Company of New Jersey. PYCO makes asbestos-free wiring harnesses for these thermocouples.
- PYCO in 1975 set the industry standard that continues today with our high-reliability spring-loaded thermocouple. This design provides a potting adapter under the spring to allow the connection of rugged stranded wires as leads. The design incorporates a twisted junction in grounded elements to insure continuity in differential expansion.
- To accommodate the demanding insulation resistance requirements of General Electric gas turbine control systems, in 1977 PYCO introduced a newly designed headless thermocouple. It worked so well, it was adapted to General Electric steam turbine use at Kentucky Power, Duke Power, South Carolina Electric & Gas and Ohio Edison, among many others.
- PYCO introduced an improved multi-point thermocouple probe for exhaust stack temperatures in Westinghouse 501 series gas turbines in 1979. The probe features ease of element replacement and long life, due to improved materials and design.
- Installation of some thermocouples was made easier in 1977 when PYCO began inserting them into bearings shipped to us by the plant in which they would be used. PYCO also provides a kit for later installation in the power plant when the bearing is rolled into place. Advancements have been made, too, in the development of thermocouple leads to seal against pressurized oil leakage.
- In cooperation with PSE&G, PYCO in 1980 began manufacturing a newly designed start-up probe with air purge and protected measuring junction.
- Pycoprobes comprise a line of unique measuring instruments for temperature, gas extraction and pressure that were introduced in 1984 for Pennsylvania Power & Light Company. PYCO since has fulfilled the needs of dozens of power plants, helping them achieve greater efficiency with the help of Pycoprobes. Since 1992, the line also includes Pycoprobes made specifically for smokestacks.
- PYCO engineers in 1989 completed the design of the primary sensors for Dresser-Rand's new high-pressure turbine. A year later, PYCO developed a high-temperature, lightweight and easy-to-handle turbine test thermocouple for acceptance and heat-rate tests. This design also includes a hook for spring loading.
- An improved design for Siemens gas turbine thermocouples was introduced in 1990, allowing for more convenient installation and removal at Delmarva Power & Light.



PYCO will continue working with all of our clients to research, design, engineer and fabricate the best possible heat-sensing and heat-control instruments from the power industry.



PYCO POWER BROCHURE

PYCO Thermocouples.
The application is up to you.
The reliability is up to PYCO.

PYCOPACK Spring Loaded Thermocouples and RTD's

PYCO's proprietary potting transition is engineered to protect the connection between sensor and stranded leadwire from failure due to vibration. Our design also insures permanent contact between the sensor tip and the thermowell for fast response and accuracy. To enhance the accuracy of today's sophisticated instruments and computer systems, PYCO's optional factory calibration certification is also recommended.

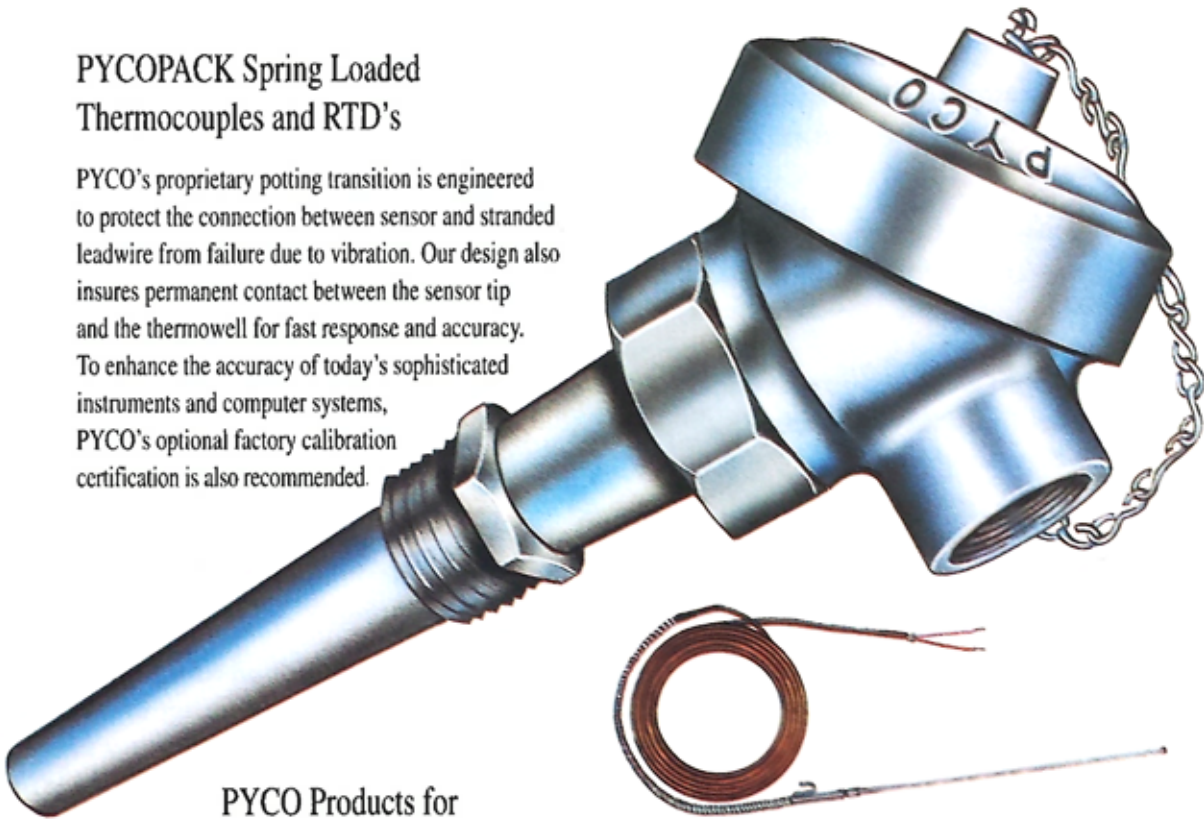

PYCO Products for Nuclear Power Plants

Re-qualified in 1983, PYCOPACK thermocouples and high temperature RTD's are nuclear tested and nuclear qualified in accordance with IEEE standard 323-1974, 344-1975 and NUREG 0588. By meeting standards for the nuclear industry, PYCO is currently on the job with turbine manufacturers and over 40 electrical utilities.

Turbine Test Thermocouples

These units are customized and calibrated for your plant's turbine acceptance and heat rate tests. The leads are Teflon® insulated and a reference junction for ice bath is available. Stainless steel spiral armor prevents stress point breakage, and the Teflon insulation protects the sensor wires from high temperatures.

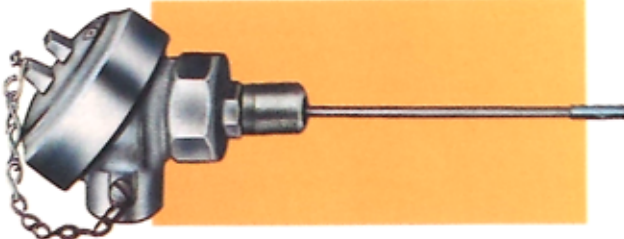

Upon request, PYCO will provide additional information and product sheets for any of the products listed in this brochure.



MULTI-POINT TEMPERATURE MEASUREMENT, FLUE GAS EXTRACTION AND PRESSURE MEASUREMENT. THE THREE-IN-ONE PYCOPROBE.

Pycoprobes

The gas samples taken through the Pycoprobe's vacuum extractive tubes make it possible for you to monitor air heater seal leakage and maintain the oxygen levels required for maximum combustion efficiency.

Pycoprobes are ideal for stack monitoring in conformance with EPA regulations.

The matrix of accurate temperature readings provided by these units in air heater ducts enables you to increase air heater efficiency, control emissions and prevent the development of corrosives like sulfuric acid.

Pycoprobes are also available for pressure applications. These in turn can be adapted for mass flow measurements.

Upon request, PYCO will provide additional information and product sheets for any of the products listed in this brochure.

Gas Pass Thermocouples

These units are available with a stainless or carbon steel 1/2" NPT protection tube, and the 1" NPT mounting bushing is set 6" below the screw cover head. The assembly contains a thermocouple element fabricated with porcelain insulated 14 gauge elements in single or duplex construction. For even longer term durability, the unit may be fabricated with a spring-loaded PYCOPACK element. Calibrations can be either J, K or E.

Bearing Thermocouples

PYCO specializes in retrofits

We can make replacements for any bearing thermocouple in your station. In fact, send us your bearings, we'll install the thermocouple for you. With PYCO every bearing thermo-

couple component is precision manufactured for precise fit. Special leadwire assemblies are also available to make oil leaks a thing of the past.

Diesel Engine Thermocouples

To take on the shock and vibration stress that go with diesel engine applications, these rugged PYCO assemblies are built with a 3/8" diameter stainless steel sheath, and 1/2" NPT stainless steel compression fittings. In addition, a strain relief spring and heavy wire braid are used to provide long term leadwire durability.

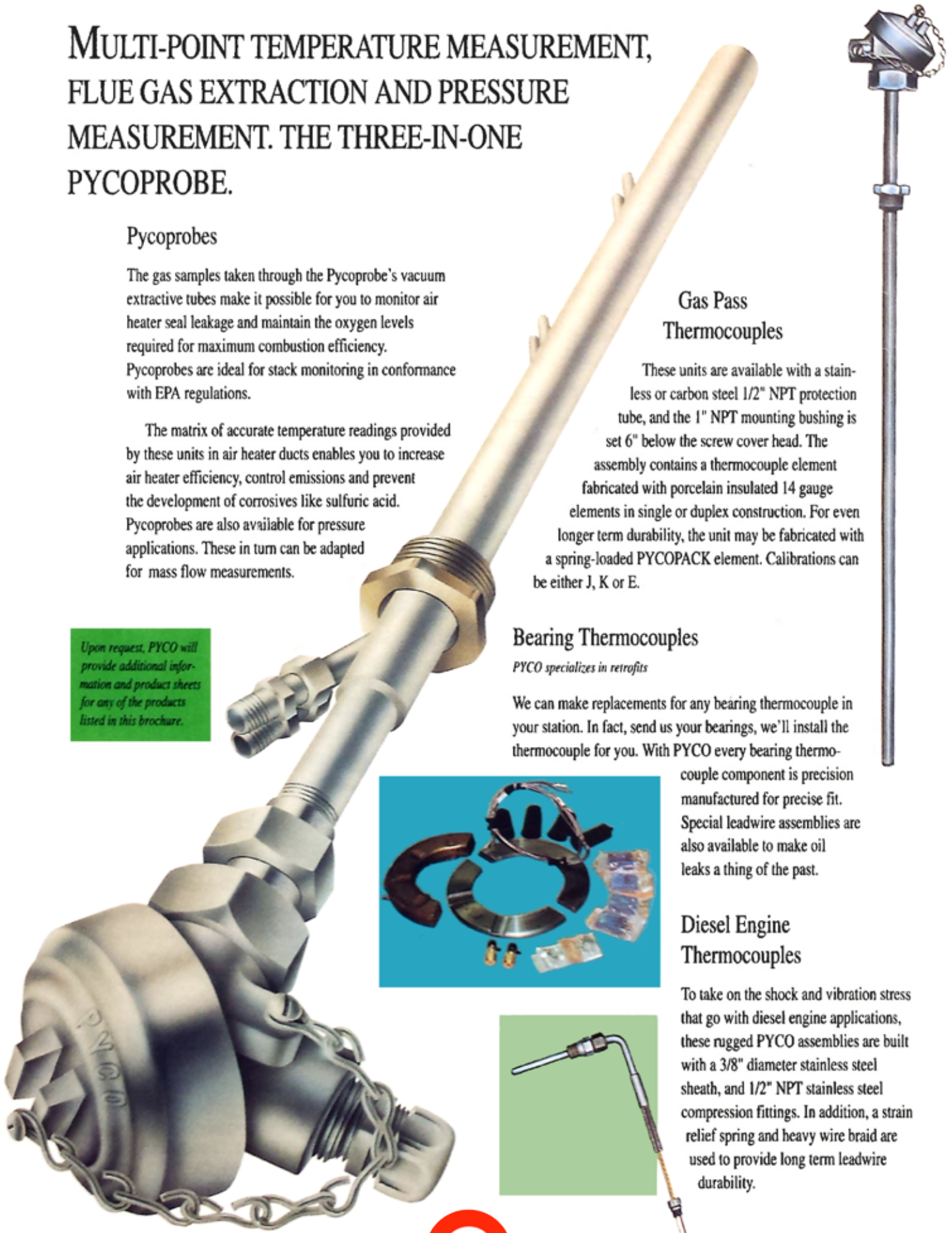

PYCO SETS THE STANDARDS. OTHERS TRY TO MEET THEM.

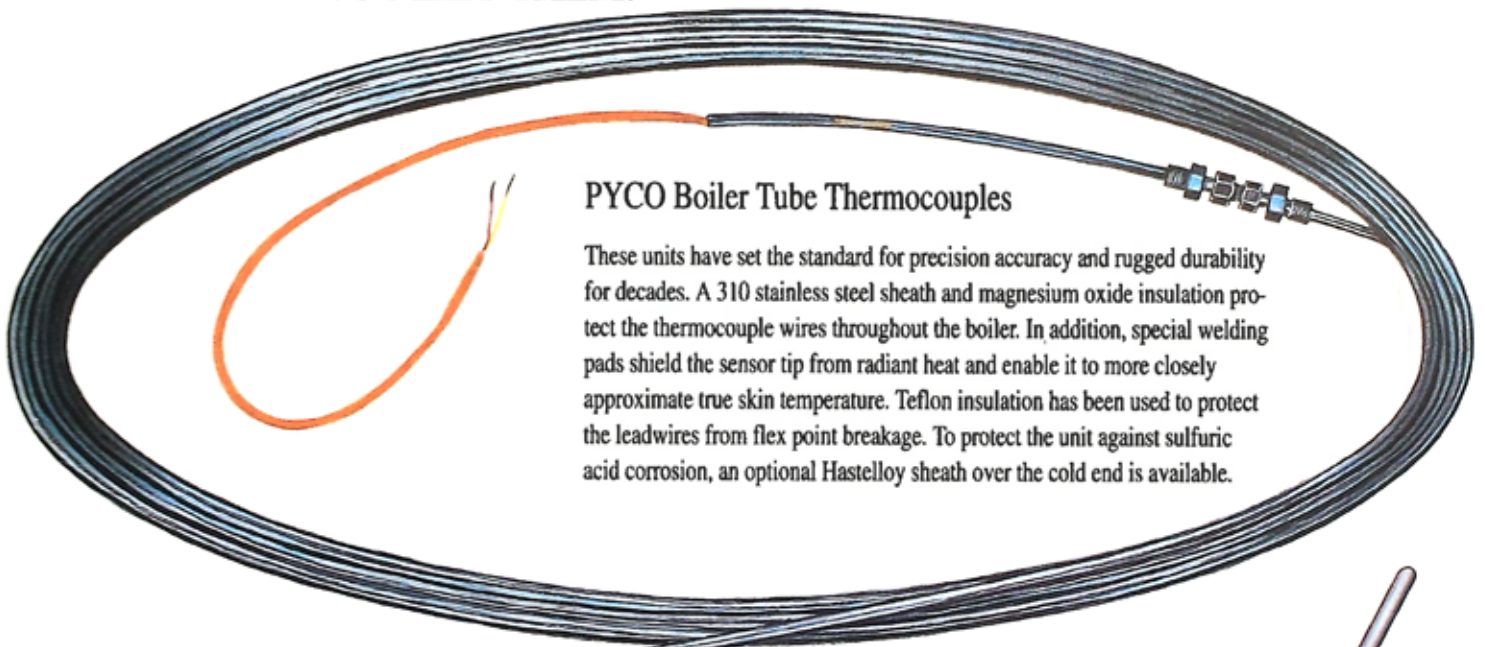

PYCO Boiler Tube Thermocouples

These units have set the standard for precision accuracy and rugged durability for decades. A 316 stainless steel sheath and magnesium oxide insulation protect the thermocouple wires throughout the boiler. In addition, special welding pads shield the sensor tip from radiant heat and enable it to more closely approximate true skin temperature. Teflon insulation has been used to protect the leadwires from flex point breakage. To protect the unit against sulfuric acid corrosion, an optional Hastelloy sheath over the cold end is available.



Magnetic Thermocouples

PYCO part #13-2012- Calib.- Lead Length

To increase stability, a spring-loaded thermocouple is mounted to the center of a sturdy magnet. This simple but effective design will firmly hold the measuring junction against the surface of the tanks, ducts, bearing housings, steam lines, and water jackets.



Spring-Loaded Oil Seal Thermocouple

Adjustable headless style: part #14-5025. Assembly with head: part #02-3046

Ideally suited for bearing applications, the spring-loaded oil seal thermocouple assembly combines the flexibility of spring-loading with the strength of "O" ring seals. Capable of containing gas pressure of 500 PSI at 500° F., these rugged thermocouples are virtually impenetrable barriers to gas and oil vapor. 1/2", 1/4" and 1/8" NPT mounting threads are provided.

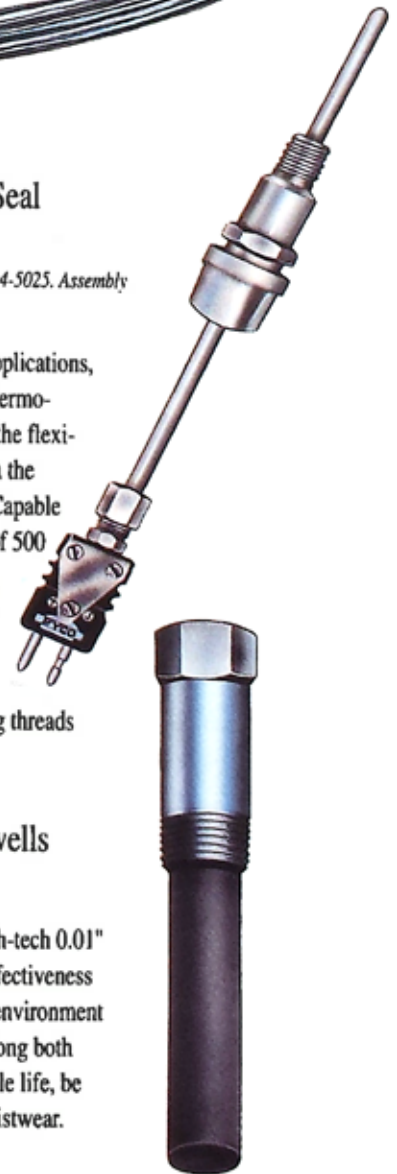

Insulator Bushings and Well Inserts

To protect your operating personnel from thermocouples that may develop high and dangerous potential on the sheath and termination heads, we have designed high quality insulating bushings and well inserts.



Resistwear Thermowells

Various Sizes

PYCO's Resistwear is a high-tech 0.01" facing that has proven its effectiveness against the highly abrasive environment of a coal pulverizer. To prolong both thermowell and thermocouple life, be sure to specify PYCO's Resistwear.



GAS TURBINE THERMOCOUPLES

PYCO offers a thorough documentation on a broad spectrum of OEM and competitive part numbers, descriptions, and drawings. As a result we are able to quickly identify and manufacture the right thermocouple for virtually any large or small gas turbine you need to monitor.

For General Electric Gas Turbines

PYCO's 02-2130 thermocouple for exhaust monitoring of G.E. models 5000 and 7000 gas turbines are identical in form, fit and function to the original parts. Our single element 02-2203 and duplex element 02-2205 are direct replacements for the 02-2130 style. The elements are continuous lengths of PYCOPACK from the measuring junction through the armor. Moreover, these rugged thermocouples are both insulated and isolated. PYCO can also supply the G.E. extended type thermocouples which require turbine modification for installation, (PYCO part numbers: 02-2269 and 02-2275).

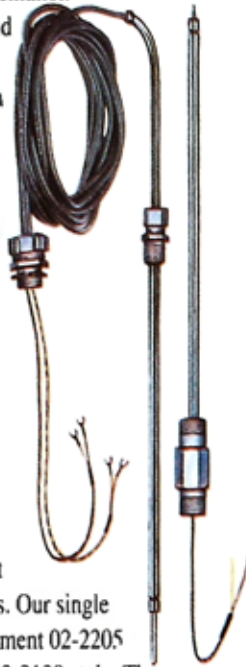

Thermocouple Part No.'s 02-9070 & 02-9071 for Heavy Duty Industrial Gas Turbines

PYCO units are regularly provided as original equipment on large gas turbines. To make sure you achieve the results you're after, these units are designed for integral mounting in our rugged 08-8031 open-ended thermowell.

Double adjustable probe for monitoring exhaust gas temperatures features the following:

- Positive seal against gas leakage.
- Adjustable measuring junction position.
- Adjustable thermocouples.
- Super rugged construction.



Harness Assembly

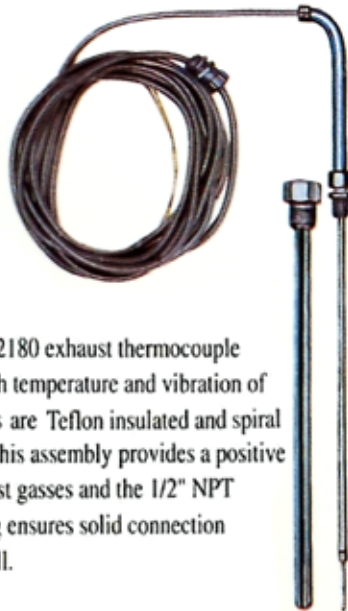

The PYCO 02-2180 exhaust thermocouple holds up to the high temperature and vibration of gas turbines. Wires are Teflon insulated and spiral armor protected. This assembly provides a positive seal against exhaust gasses and the 1/2" NPT compression fitting ensures solid connection with the thermowell.



STABILITY UNDER FIRE

PYCO Spring Loaded Thermocouples
Engineered Reliability For Over 30 Years.

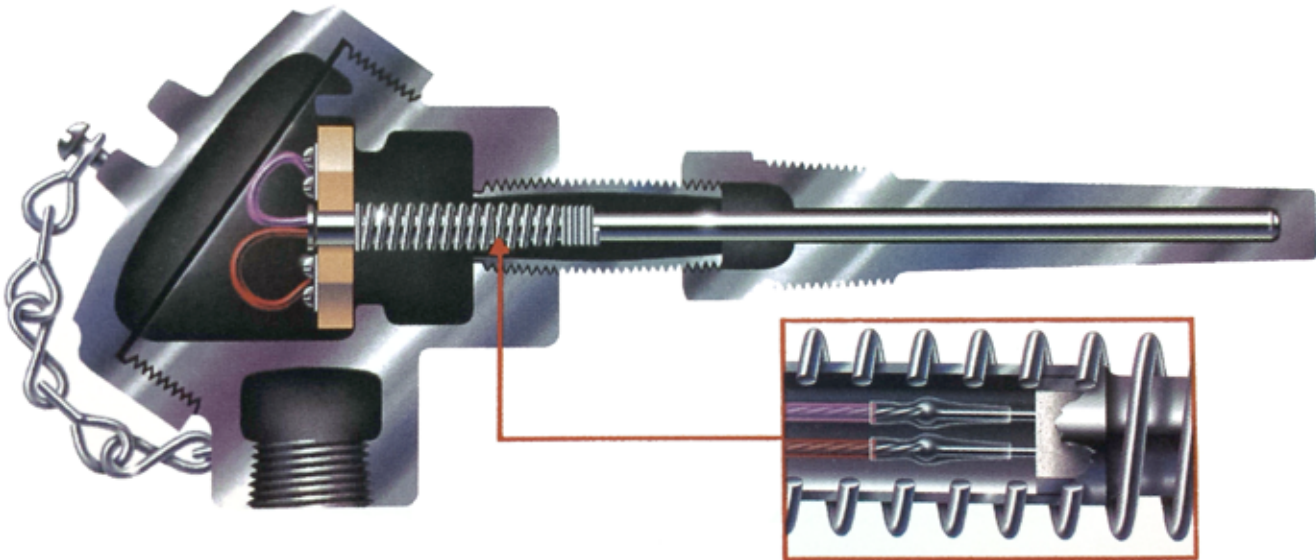

PYCO spring loaded thermocouples can maximize fuel efficiency and minimize the risk of damage to plant equipment by providing boiler operators with accurate temperature readings.

The accuracy and reliability of the thermocouples you use are critical when you consider that a 400-megawatt unit can lose the output equivalent to \$30,000 a year if old or worn monitoring equipment has it operating at 995°F. but reading at 1000°F. Conversely, heat rates higher than planned are generated when sensors read low, creating stress on boilers and turbines that can shorten the life of plant equipment.

PYCO spring loaded thermocouples are ideal for all critical temperature measurement locations such as main steam, reheat steam, crossover steam or turbine inlet.

Factory calibration option

PYCO also offers reasonably priced factory calibration certification—an added measure of accuracy and reliability that ensures maximum precision in measurement and control. Scheduling periodic replacement of the sensors in your steam lines can also save you money by avoiding minor problems and protecting against major ones.

Excellence in design, engineering, materials and fabrication have been the hallmark of PYCO products since 1958. Doesn't your equipment deserve PYCO reliability?



REPEATABILITY AND RELIABILITY. THE RESULTS YOU'RE AFTER COME FROM PYCO.

Spring Loaded Thermocouples

*Precision
Engineering
For Precision
Performance.*

Thermocouple Sensors

- 304 stainless steel sheath is used to encapsulate sensor wires.
- Magnesium oxide insulation creates a neutral atmosphere which fully protects conductors from moisture, corrosives, and destructive particulates.
- Differential expansion between the sheath and the thermocouple element will not destroy the junction or produce an open circuit.
- Optional factory calibration provides the correction data for enhancing the accuracy of today's sophisticated instruments and computer systems.

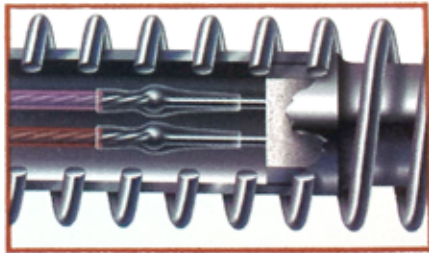

Easy to Specify

All PYCO spring loaded thermocouples are custom-built and guaranteed to fit. In addition, we've simplified the specification procedures to make it easy to order the assemblies your system requires.

- On your initial purchase tell your PYCO representative the well cavity depth.
- To achieve the results you're after, we recommend specifying terminal block, head and nipple, or nipple-union-nipple assembly.
- Information on ordering replacement sensors can be found on PYCO product sheet 202.

Proprietary Potting Adaptor

- Potting adaptor rated to 750°F.
- Stranded leadwires form a secure but flexible connection to the vibration-proof block.
- Problems of cold-worked and broken leads are virtually eliminated.
- With insulated junctions, conductors are isolated from both the sheath and each other.
- Each pair of wires in every grounded junction is twisted and welded before being connected to the end closure.

Stainless Steel Spring

- Permits free linear movement of the sensor.
- Creates constant contact between the tip of the sensor and the bottom of the thermowell to assure accuracy.
- Retards wear from vibration.

Nuclear Tested. Nuclear Qualified.

- PYCO spring loaded thermocouples measure up to the highly demanding LOCA tests.
- Elements and assemblies have been nuclear tested through exposure to thermal aging, radiation, and seismic conditions.
- PYCO spring loaded thermocouples are nuclear qualified in accordance with IEEE Standard 344-1975 and NUREG 0588.





Other Services

- Experience Engineers
- AutoCad Services
- Wake Frequency Calculations
- Design
- Customer Inspection Manuals
- Quality Inspection Plan
- Qualification Records
- NIST Calibration

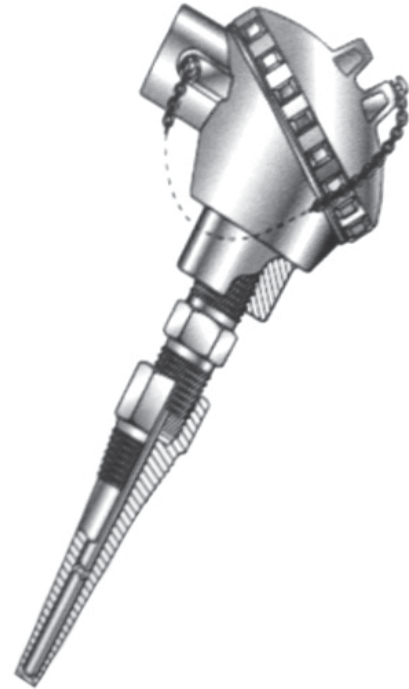



Our Value

- 80+ years of combine experience
- A Quality and Reliable Service
- Personalized Service
- A full service manufacturer with technical support such as engineering and design service, testing, calibration, and distribution of accessories to enable us to offer a complete solution to the industry.
- Commitment to a superior customer and partner Relationship
- 24/7 Service
- Our Experience in your hands



***“Serving One Customer
At a Time”***





PYCO, LLC.

600 E. LINCOLN HWY.
PENNDDEL, PA 19047
215-757-3704
Fax: 215-757-3780

1275 BLOOMFIELD AVE.
BUILDING 5, UNIT 24
FAIRFIELD, NJ 07004
862-701-4506

info@pyco.com



www.pyco.com





The Sensor People



PYCO, LLC.

600 E. LINCOLN HWY.
PENNDL, PA 19047
215-757-3704
Fax: 215-757-3780

info@pyco.com

1275 BLOOMFIELD AVE.
BUILDING 5, UNIT 24
FAIRFIELD, NJ 07004
862-701-4506

• www.pyco.com

SATISFYING ONE CUSTOMER AT A TIME