

IMMERSION RTD

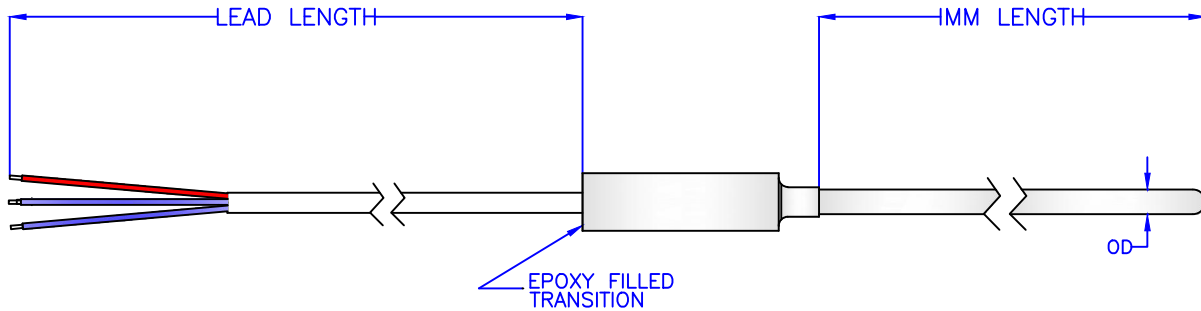

EXAMPLE ORDERING CODE:

IMM RTD-250-LT-12-24-T-S-B-BE

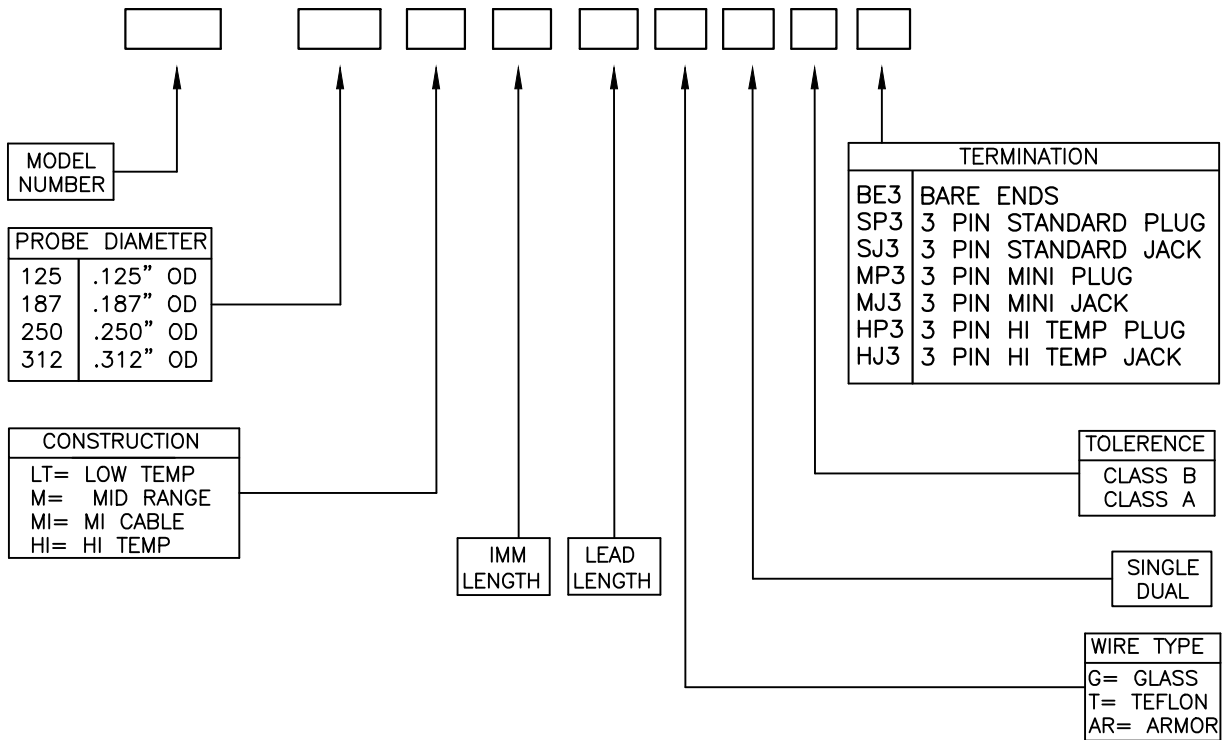

PLATINUM RTD ELEMENT: .00385 TRC, 100 OHM @ 0 DEG C
SPECIAL RTD ELEMENTS AVAILABLE UPON REQUEST

LT TEMPERATURE RANGE: -50F TO 500F
M TEMPERATURE RANGE: -50 TO 750F
MI TEMPERATURE RANGE: -290 TO 930F
HT TEMPERATURE RANGE: -290 TO 1,200F

2 WIRE AND 4 WIRE RTD'S ARE
AVAILABLE UPON REQUEST