

INDUSTRIAL TUBE SKIN THERMOCOUPLE

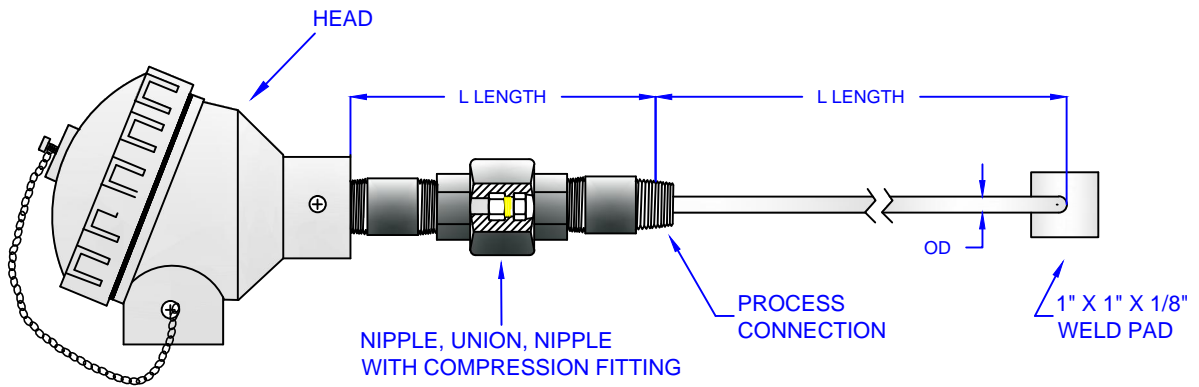

EXAMPLE ORDERING CODE:

IND TSTC - 250 - JS - G - 304 - L3 - 3/4 - 48 - 6 - AL

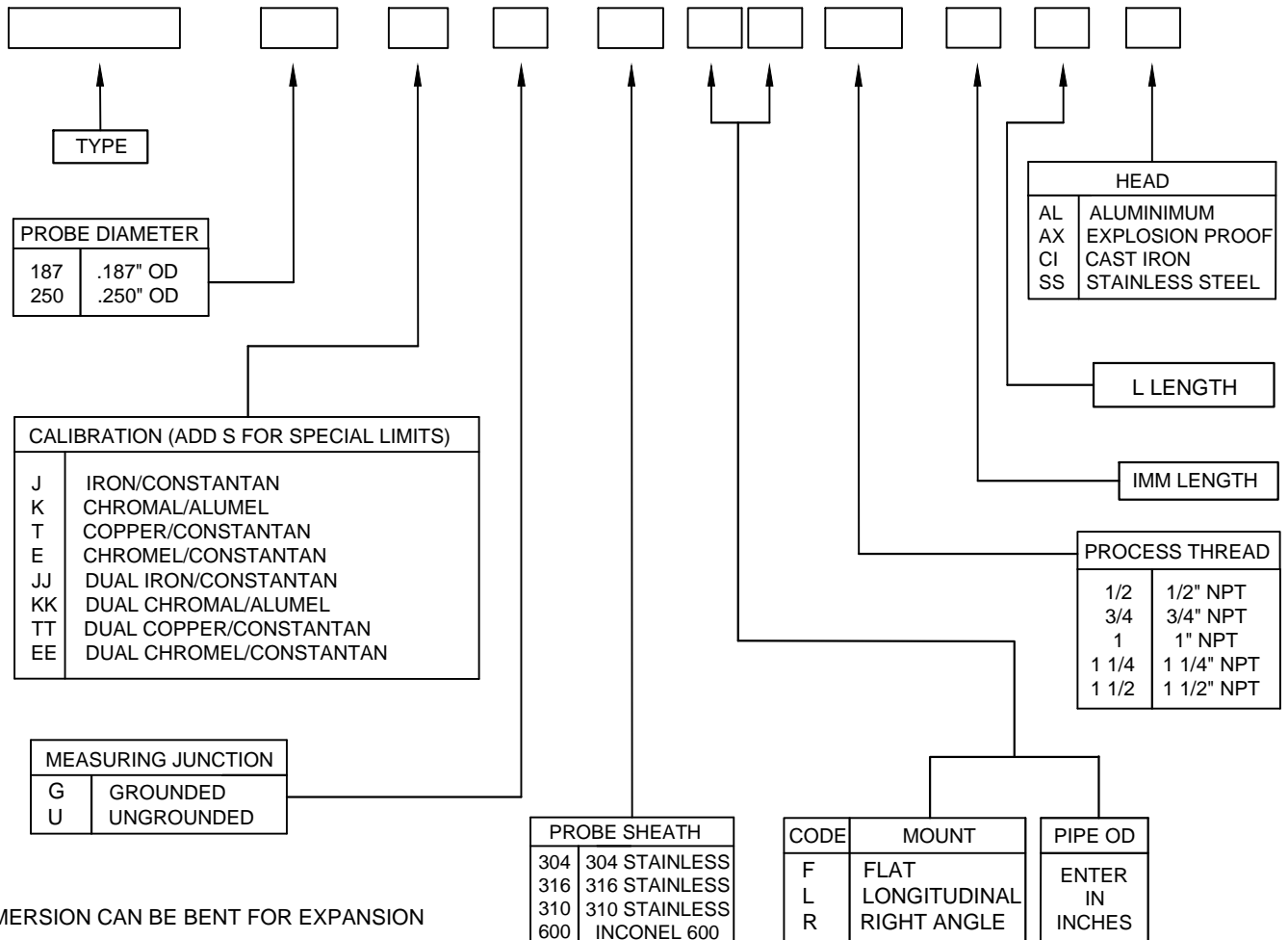

IMMERSION CAN BE BENT FOR EXPANSION

SPECIAL DESIGNS OR MATERIALS UPON REQUEST

MEETS ANSI AND ASTM STANDARDS FOR THERMOCOUPLE CALIBRATION TOLERANCES

ELEMENT SHIPPED SEPARATELY FOR EASY PROCESS INSTALLATION