

# INDUSTRIAL THERMOCOUPLE - LESS WELL

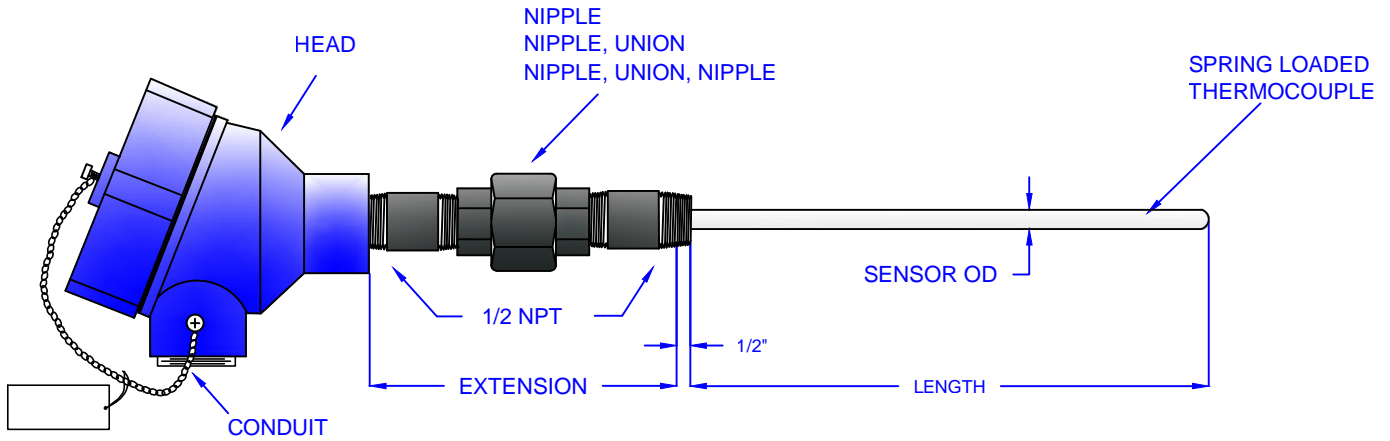

EXAMPLE ORDERING CODE:

**IND TC - AX - 3/4 - 250 - 304 - K - G - NUN6 - 12.5 BN**



MODEL NUMBER

HEAD	
AL	STANDARD ALUMINUM
AX	ALUMINUM EXPLOSION PROOF
CI	CAST IRON
SS	STAINLESS STEEL

CONDUIT THREAD	
1/2	1/2" NPT
3/4	3/4" NPT

PROBE DIAMETER	
125	.125" OD
187	.187" OD
250	.250" OD
312	.312" OD
375	.375" OD

PROBE SHEATH	
304	304 STAINLESS
316	316 STAINLESS
310	310 STAINLESS
600	INCONEL 600

EXTENSION - LENGTH		
N	NIPPLE	3"
NU	NIPPLE UNION	3"
NUN	NIPPLE, UNION, NIPPLE	6"

JUNCTION	
G	GROUNDED
U	UNGROUNDED

CALIBRATION (ADD S FOR SPECIAL LIMITS)	
J	IRON/CONSTANTAN
K	CHROMAL/ALUMEL
T	COPPER/CONSTANTAN
E	CHROMEL/CONSTANTAN
JJ	DUAL IRON/CONSTANTAN
KK	DUAL CHROMAL/ALUMEL
TT	DUAL COPPER/CONSTANTAN
EE	DUAL CHROMEL/CONSTANTAN

LENGTH BELOW NIPPLE OR UNION