

PLASTIC MELT RTD

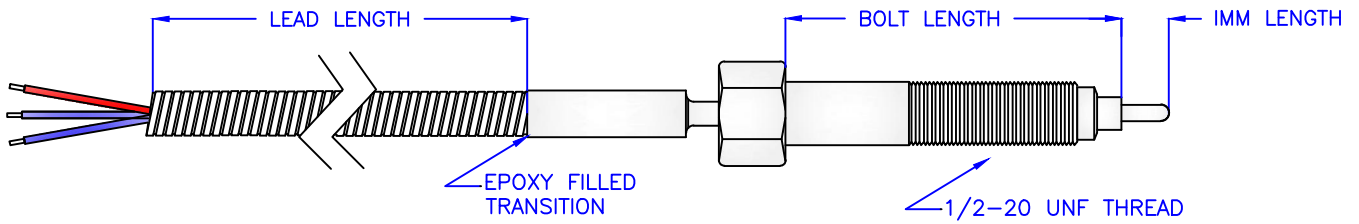

EXAMPLE ORDERING CODE:

PM RTD-125-LT-3-.5-24-T-S-B-BE

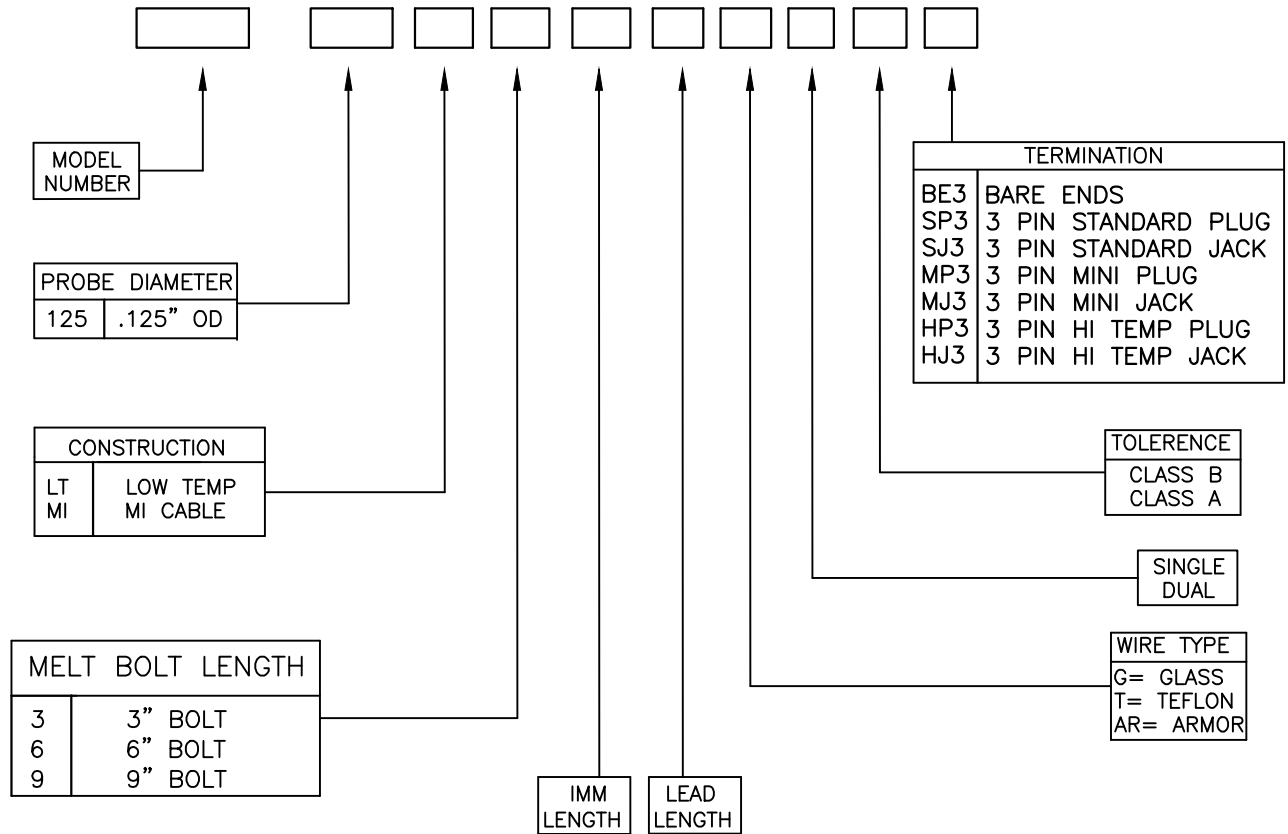

PLATINUM RTD ELEMENT: .00385 TRC, 100 OHM @ 0 DEG C
SPECIAL RTD ELEMENTS AVAILABLE UPON REQUEST

LT TEMPERATURE RANGE: -50F TO 500F
MI TEMPERATURE RANGE: -290 TO 930F

2 WIRE AND 4 WIRE RTD'S ARE
AVAILABLE UPON REQUEST